



...PORTA-GANTRY[®]

5000



ASSEMBLY VIDEO

Assembly & Operation

www.reidlifting.com

REID
LIFTING
LIGHTWEIGHT | PORTABLE | SAFE

No. 1 in lightweight, portable, safe lifting solutions

CONTENTS

INTRODUCTION

CORRECT OPERATION

- Inspection Prior To Initial Operation
- Inspection Before Starting Work
- Maximum Capacity
- Notes For Correct Usage
- Warning
- Attaching The Load
- Temperature Range
- Regulations
- Inspection/Maintenance
- Regular Inspections
- Maintenance/Repair
- Marking
- ATEX
- Language

ASSEMBLY INSTRUCTIONS

- Mechanical Aid Assembly
- Alternative Gantry Assembly
- Beam Height Adjustment

VARIANTS AND OPTIONS

- A-Frame and Stabilizer Leg
- Wind Up Jack Legs
- Customised Configurations
- PORTA-GANTRY 500-3000
- PORTA-GANTRY RAPIDE

DETAILED DIMENSIONS

QUALITY & SAFETY

- Accreditations

INSPECTION RECORD

INTRODUCTION

All users must read these operating instructions carefully prior to the initial operation. These instructions are intended to acquaint the user with the machine/hoist and enable him/her to use it to the full extent of its intended capabilities.

The operating instructions contain important information on how to handle the gantry in a safe, correct and economic way. Acting in accordance with these instructions helps to avoid dangers, reduce repair costs and down time and to increase the reliability and lifetime of the gantry.

Anyone involved in doing any of the following work with the gantry must read the operation instructions and act accordingly:

- operation, including preparation, troubleshooting during operation and cleaning
- maintenance, inspection, repair
- transport

Apart from the operating guide, health & safety and accident prevention act valid for the respective country and area where the gantry frame is used, the commonly accepted regulations for safe and professional work must be adhered to.

It is incumbent on the user or instigator of work with the equipment that all users have suitable medical and physical capabilities. Likewise the competent person should ensure there is a rescue plan in place in the event of an emergency that could occur during the work.

N.B. This document should form an element of the overriding Risk Assessment and Method Statement required for each lift.

No. 1 in lightweight, portable, safe lifting solutions

CORRECT OPERATION

Inspection prior to initial operation

Each *PORTA-GANTRY* must be inspected prior to initial operation by a competent person. The inspection is visual and functional and shall establish that the structure is safe and has not been damaged by incorrect assembly, transport or storage. Inspections are instigated by the user.

Inspection before starting work

The inspection procedure requires that a valid inspection/test certificate has been submitted to and checked by the user.

Before starting work inspect the gantry assembly and all load-bearing components for visual defects. Check the integrity of all profiles for denting and bolt holes for wear and elongation. Furthermore, test the trolley for free movement along the beam.

Ensure that the overall working load limit (WLL) limit is adhered to – following the necessary Risk Assessment and Method Statement.

Maximum capacity

The *PORTA-GANTRY* is designed to lift and lower loads up to its rated capacity. The capacity indicated on the frame is the maximum working load limit (WLL) or safe working load (SWL) which must not be exceeded (definition is country dependent).

When being used as a personnel lifting anchor the user must use a body harness and retractable device or shock absorber to EN355, ANSI Z359.6-09 or CSA Z259.16-04 that limits the maximum allowed force (M.A.F.) to 6kN. Winches used with the *PORTA-GANTRY* should comply to EN1496:2017 or equivalent.

Only ONE person / load may be attached to ONE trolley in accordance with the WLL's.

The gantry has an up-rated capacity for personnel positioning. This is when the structure is to be used as an anchor for lifting persons that have a suitably

low chance of falling through a free distance and only carried out following a comprehensive risk assessment.

While the *PORTA-GANTRY* has the capacities stated in the table below, it is only one part of a fall arrest system which is only as strong as its lowest rated component. Each lift must be properly planned and all weights clearly known along with the WLL's and constraints of all fall arrest system devices.

The capabilities stated in the table below are only applicable to standard range *PORTA-GANTRY* systems with a 5000kg working load limit. Bespoke versions of the gantry are available tailored to specific lifting needs. If unsure about your system consult serial labels, information filled in on page 23 or consult your supplier. A custom gantry is designated by a product number ending with a "C" found on the serial label attached to each A-frame and the beam. For custom designed gantries please contact your supplier for appropriate rating and capabilities.

In the event of simultaneous goods and personnel combined lifting or when being used as a fall arrest system in sub-zero AND wet conditions contact the supplier as capacities may be reduced.

Application	Capacity
Goods [kg]	5000
Fall Arrest*	5 persons
Max. Combined Personnel Lifting Capacity [kg]	2000

*N.B. Only applicable to *PORTA-GANTRY* systems being used in accordance with PD CEN/TS 16415:2013. When being used in accordance with EN795:2012, the structure shall be limited to a maximum of one user in fall arrest.

NOTES FOR CORRECT USAGE

- We recommend the use of load-sensing or overload protection devices on all lifts.
- The risk assessment & method statement must consider additional loading resulting from any “wet lift” situations.
- Ensure suitable winches and connection plates are used for all applications.
- Due care and attention should be practiced when transporting and storing the gantry to avoid damage.
- Do not throw the gantry or its components down or stack items on top of it. Always place properly on the ground avoiding damage to the equipment.
- Assemble only as instructed (ensure all bolts are present and fitted correctly as per instructions).
- We recommend that gloves should be worn when using this equipment.
- Set up the gantry at a safe distance from the hazard and subsequently move the structure into place.
- The beam must be horizontal prior to any lift and A-frames vertical and parallel to each other.
- Do not use the gantry if the trolley does not run freely along the beam.
- Attach hoist only to the lifting point on the trolley.
- Avoid side pull. Lowering and lifting should only be carried out when the load chain/lifeline form a straight and vertical line between the load and lifting attachment point on the trolley.
- Do not allow load to swing.
- When lifting keep the load low to the ground.
- NEVER walk away from structure whilst still being connected.
- Only raise and lower loads when **CASTOR BRAKES** are **ENGAGED**.
- When using the gantry as a fall arrest anchor the required clearance of the fall arrest device should be considered - refer to device’s Operations & Maintenance manual and consider the height adjustment on the gantry.
- Before the gantry is used consideration must be given to the potential effects of the lifelines over sharp edges, chemical reagents, electrical conductivity, cutting, abrasion, climatic exposure and the effect of offset forces as a result of pendulum falls.
- The gantry is not to be moved under load except when a Competent Person or authority approves a risk assessment and a method statement for a particular reason.
- To ensure stability of the structure, the operating span of the beam must be equal to or greater than the distance between the castors on the A-Frame.

Warning

- The equipment shall not be used outside its limitations, or for any purpose other than that for which it is intended.
- When winching only one lifeline should be used with each sheave and they should never cross paths with each other.
- Do not lift or transport loads while personnel are in the danger zone.
- Do not allow personnel to pass under a suspended load.
- When gantry is used with multiple persons attached working procedures should dictate that individual lifelines do not cross and become tangled.

No. 1 in lightweight, portable, safe lifting solutions

- It is NOT recommended to mix the use of the gantry with personnel and goods lifting concurrently.
- A suspended load must not be left unattended.
- Start moving the load along the beam only after it has been attached correctly and all personnel are clear of the danger zone.
- Be aware of hazards when setting up/folding down, eg. hands/fingers trapped in rotating parts.
- It is essential for safety that the PORTA-GANTRY is withdrawn from use immediately should:
 - 1) any doubt arise about its condition for safe use or;
 - 2) it has been used to arrest a fall and not be used again until confirmed in writing by a competent person that it is acceptable to do so.

Attaching the load

The operator must ensure that the hoist is attached in a manner that does not expose him or other personnel to danger by the hoist, chain(s) or the load.

Temperature range

The PORTA-GANTRY can be operated in ambient dry temperatures between -20° and +55°C (-4°F to 131°F). Consult your supplier in case of extreme working conditions.

If used in sub-zero and wet conditions, fall arrest appliances characteristics may change.

Regulations

The PORTA-GANTRY complies with the following regulations:

PPE Regulation (EU) 2016/425, Machinery Directive 2006/42/EC, The Provision and Use of Work Equipment Regulations 1998 (S.I. 1998 No. 2306), The Lifting Operations and Lifting Equipment Regulations 1998 (S.I. 1998 No. 2307). The safety regulations of the respective country for using manual lifting equipment must be strictly adhered to. EN795:2012, PD CEN/TS 16415:2013, ANSI Z359.18 and CSAZ259.16-15 certified.

INSPECTION/MAINTENANCE

Regular inspections

To ensure that the gantry frame remains in safe working order it must be subjected to thorough periodic inspections by a competent person. Inspections are to be 6 monthly for personnel lifting and 12 monthly for goods only unless adverse working conditions or profile of use dictate shorter periods. The components of the gantry frame are to be inspected for damage, wear, corrosion or other irregularities. To check for worn parts it may be necessary to disassemble the gantry frame.

Repairs should only be carried out by an approved specialist workshop that uses original spare parts.

If using the Gantry in explosive atmospheres see additional section titled ATEX.

Inspections are instigated by the user. If detailed information is required on inspection and test criteria, please refer to your supplier's technical department.

Please refer to pg 23 for the equipment inspection log.

Maintenance/Repair

In order to ensure correct operation not only the operations instructions, but also the conditions for inspection and maintenance must be complied with. If defects are found **stop** using the PORTA-GANTRY immediately.

No alterations or additions to the equipment should be made without the written consent of the manufacturer. Any repair shall only be carried out in accordance with the manufacturer's procedures.

It is recommended to maintain the equipment in a clean and dry manner. Cleaning is suggested using a sponge or cloth with warm, soapy water (using diluted domestic washing up liquid), rinsing and allowing to dry.

Marking

The serial labels indicate:

- The product identification number.
- The products unique serial number.
- The goods WLL of the device.
- The year of manufacture.
- The standards to which the device is approved.
- The ATEX rating of the product (if applicable) - see ATEX section below.
- CE 0088: Notified body number (currently LRQA) who are responsible for approving REID Lifting's quality control system.



Read the Assembly & Operation instructions.



PORTA-GANTRY 5000kg
Assembly & Operation instructions.



Risk Assessment
Please use this risk assessment as a guide only, all customers must complete their own method statement and risk assessment to suit the environment in which the equipment is being used.



ATEX

This product has been designed for use in explosive atmospheres. If the product is to be used in explosive atmospheres then the following section must be followed. Any different or exceeding use is considered incorrect and REID Lifting Ltd will not accept any responsibility for damages resulting from false application. The risk is solely with the user. If the product has been customised in any way then it may not comply with standards and not be suitable for use in explosive atmospheres. If this is the case then the product will not have any of the below marking. If in doubt contact your REID representative.

ATEX - Classification

As standard, the product meets the requirements of Category 3 equipment for use in Zone 2 explosive atmospheres, providing a normal level of protection where mixtures of air and gases, vapours or mists or by air/ dusts mixtures are unlikely to occur or, if they do occur, are likely to do so only infrequently and for a short period only.

ATEX - Identification

In addition to the previous marking section the product will have the following identification on the serial label:

As standard for Zone 2 atmospheres:

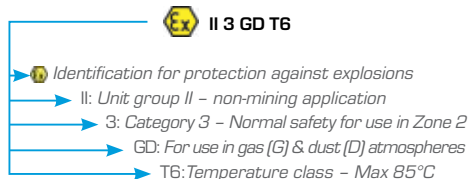

No. 1 in lightweight, portable, safe lifting solutions

ATEX - Spark Formation

Increased danger of ignition may emanate from clashing of special material pairings. These are non corrosion-resistant steel or cast iron against aluminium, magnesium or pertinent alloys. This applies especially in case of rust or surface rust. When assembling the product and inserting fastening components; they must be clear of rust and debris of any kind. Care must be taken to ensure the product is handled in a suitable manner and is never thrown, and always placed, onto the ground.

ATEX - Static Electricity

For Zone 2 applications static electricity has been identified as potential for build up leading to an incendive spark. Although the risk of such ignition is unlikely the gantry must be earthed during assembly and use. This can be achieved by attaching a 4mm earthing lead to a convenient location on metallic parts of both the Gantry and Trolley.

ATEX - Inspection, Maintenance & Repair

If using the gantry in explosive atmospheres, in addition to the regular inspection/ maintenance information found on page 6, these additional instructions should be followed.

Inspections shall be instigated by the user and occur at least 6 monthly or sooner if adverse operating conditions or profile of use dictate shorter periods. Inspections and maintenance shall be carried out at a safe distance away from an explosive atmosphere. Special attention should be given to dust deposits on the structure, especially in areas where the profiles come into contact, and should be wiped clean and care taken not to apply materials that could create electrostatic charging. Additionally the bearings in the trolley rollers and castors should be checked to ensure they rotate freely. The structure is predominantly constructed from aluminium which will not rust. However there are steel components used throughout. These are the fasteners, castors, master-link, trolley rollers, A-frame height adjustment gearing system (if fitted) and the height adjustment ratchet (if fitted). Where there is sign of any rust deposits on the aluminium structure it should be wiped clean as above and where there is sign of rust on a steel component then that component should be removed from use and the structure not used until a replacement is fitted.

LANGUAGE

It is essential for the safety of the user that if this product is re-sold outside the original country of destination the reseller shall provide instructions for use, maintenance, for periodic examination and for repair in the language of the country in which the product is to be used.

ASSEMBLY INSTRUCTIONS

N.B. Appropriate PPE should be worn • Gloves • Protective footwear • Hard hat

1. *PORTA-GANTRY* system delivered flat packed on a pallet:

- 2 x A-Frames
- 1 Trolley
- (Stabiliser legs – Option)



2. Gantry Tool Set: (supplied as an option)

- Ratchet handle
- 24mm socket
- 24mm combination spanner
- 14mm long series allen key



3. A-Frame prior to assembly



4. Assemble each A-Frame by:

- Positioning legs and bolt in place
- Attaching leg brace

The unit is most easily assembled with the A-Frames at their lowest height setting and this is the recommended position to start from. **(A-Frame shown with Geared elevation and Stabiliser leg attached)**



PORTA-GANTRY® 5000

No. 1 in lightweight, portable, safe lifting solutions

5. Apply the castor brakes.

Put brakes on only with protective footwear ensuring that the castors are in the orientation shown.

Do not use hands

Lock castors in position in line with the A-Frame Tie Bar, as shown:

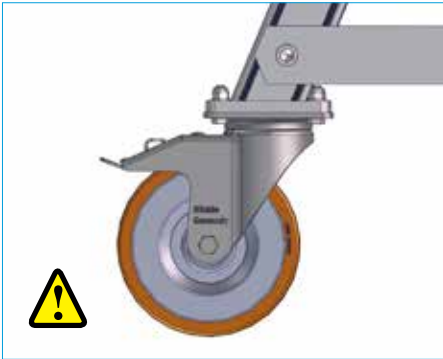

6. Cheek Plates bolts 1 and 2

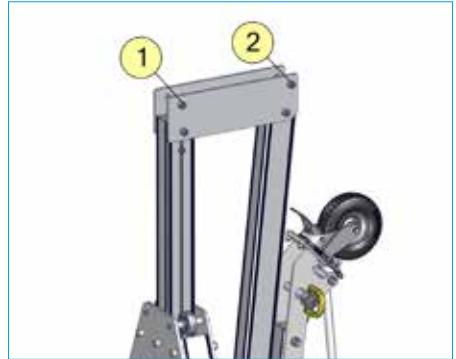

7. Lay the two A-Frames a beam length apart on a flat surface in line with each other with the castor wheels outward and brakes on.

Lay the beam on the A-Frames, resting on Bolt 1 on each cheek plate.



8. Offer one end of the beam to the rear bolt-hole on the cheek-plate (Bolt 1) and insert a bolt. Put on plain and spring washers and nut, finger tight.



9. Thread beam trolley over the other end of the beam and lock with friction brake at approximately the centre position. Offer the beam to the rear bolt-hole on the cheekplate (Bolt 1) and insert a bolt. Put on plain and spring washers and nut finger tight until spring washer depressed. Assess whether the lifting device (usually chain block / hoist) needs to be attached to the trolley at this stage or when fully assembled. Heavier hoists are best attached at this stage to avoid lifting and working at height.

Note: The gantry beam has adjustment holes to narrow the footprint of the gantry. This is best done when the gantry is assembled with 2 persons sliding the A-frame inwards while 1-2 persons steady the gantry by holding the beam – this will require the use of a step ladder. If this process is required to be carried out often then an upgrade to 'lobed cheek plates' can be purchased which allows the gantry to be assembled as steps 8-21 but with one A-frame inward from the end of the beam.

10. Visual Check

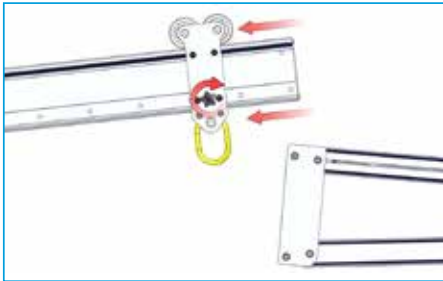

Mechanical Aid Assembly

11. Move trolley to last beam hole on side of A-frame to be assembled and insert spare bolt into beam, between trolley and A-frame to be assembled, as shown. Fasten bolt with nut to ensure it does not remove itself. **(N.B. the further the trolley away from the A-frame the greater the mechanical advantage)**

12. Attach chain block to trolley master-link and attach the lifting chain to the mechanical aid, as shown.

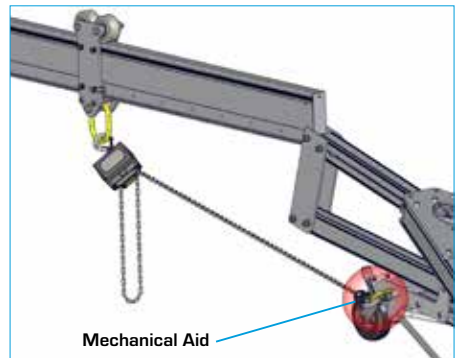
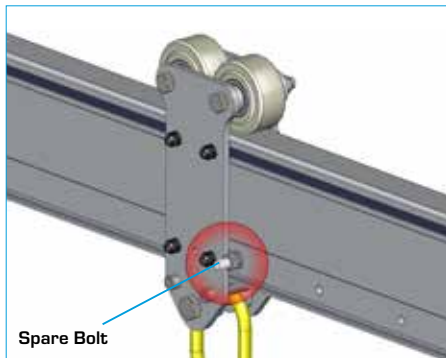

PORTA-GANTRY® 5000

No. 1 in lightweight, portable, safe lifting solutions

13. Operate chain block until A-frame assembly perpendicular to beam and assembly bolt holes in cheek plate and beam line up. Ladder will be required to reach bolt holes. Insert the second bolt into the cheek-plate. Tighten both bolts until spring washer is fully depressed.

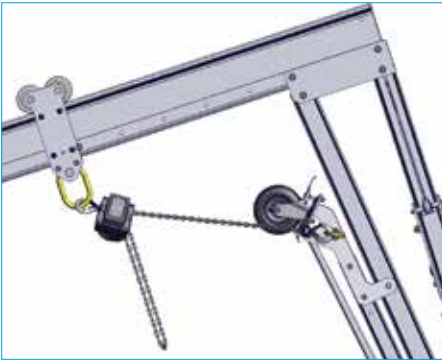

14. Slacken chain block and remove bolt restraining trolley.
15. Move trolley to other end of beam and repeat steps 11 to 13 for second A-frame assembly. Then follow step 20.

Alternative Gantry Assembly



16. If mechanical aid assembly not possible proceed as follows:

Secure trolley at opposite end of beam to be assembled and secure by tightening trolley knob.

With the help of 2 (or 3) people, scissor the beam and A-Frame into position (using the first bolt as a hinge until A-frame assembly perpendicular to beam).

Be careful not to trap any fingers in this operation.

17. Insert the second bolt into the cheek-plate. Tighten both bolts. (Do not over tighten)

N.B. The use of a suitable platform ladder may be required to reach the bolt-hole.

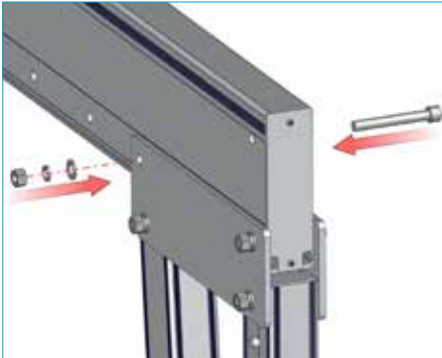

19. Insert and tighten the final beam bolt.

N.B. Again, the use of a suitable platform ladder may be advisable to reach the bolt-hole.



18. Move trolley to other end of beam, opposite to the end to be raised, and secure by tightening the trolley knob. (For additional safety whilst the beam is at such an angle a spare bolt can be temporarily placed in an adjustment point on the beam to prevent the trolley slipping down the beam).

Repeat the scissor activity at the opposite end of the gantry - Steps 16-18.



20. If the hoist is not already attached to the suspension point on the trolley, do so now (using step ladder if height setting requires).

If this is not safe, disassemble the gantry and re-start adding the hoist prior to raising the A-Frames - Step 9.



PORTA-GANTRY® 5000

No. 1 in lightweight, portable, safe lifting solutions

21. The gantry is now erect at its lowest height setting.

Tighten all bolts to 27 Nm (20 ft lbs)

(If raising the beam height – leave the two height adjustment bolts loose on each upright –see next image).

Decide on the height required (always using the lowest setting for the work in hand).



22. Release trolley brake and castor brakes to position the gantry over the load ensuring, when possible, that the load is lifted from the center of the beam.

N.B. ENSURE THE BEAM IS HORIZONTAL AND CASTORS ARE LOCKED PRIOR TO ANY LIFT.

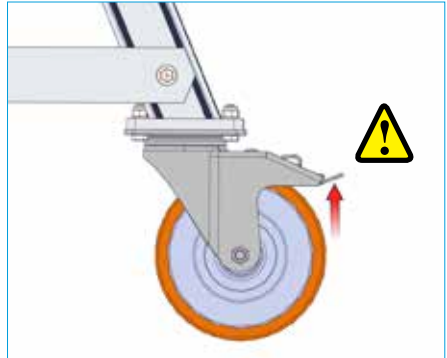

23. Beam Height Adjustment

A) A-Frames with Geared Handwheel:

Two Person Operation is Recommended – one on each A-Frame working concurrently.

For taller A-Frames suitable platform ladder should be used to operate the gearwheel at an ergonomic height.

1. Decide on the height required (always use the lowest setting for the work in hand).
2. Ensure the castor brakes are on.
3. Hold the A-Frame wheel securely.



4. Remove the 2 upright bolts, as shown above.
5. Compress centre button with thumbs whilst holding the wheel firmly.
6. Rotate the wheel (clockwise to raise, anti-clockwise to lower) to adjust height to required setting, ensuring that the bolt holes are aligned.



7. Decompress centre button, but continue to hold wheel securely.

8. Re-secure with 2 upright bolts, nuts and washers.

9. The above steps 4-8 to be done concurrently on each A-Frame, ensuring that both A-Frames finish at the same height.

10. Check all bolts on the gantry are secure.

11. If the hoist is not already attached to the suspension point on the trolley, do so now (use a suitable platform ladder if height setting requires). If this is not safe, disassemble gantry and re-start from step 9 of the Gantry Assembly Instructions.

N.B. Ensure the beam is horizontal prior to any lift.

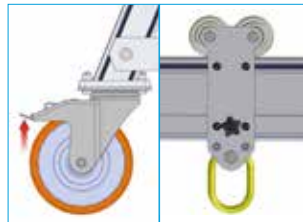

Release trolley brake and wheel brakes to position the *PORTA-GANTRY* directly over the lifting point.

No. 1 in lightweight, portable, safe lifting solutions

B) A-Frame with Ratchet System:

Two Person Operation Recommended – one on each A-Frame working concurrently.

Always wear gloves when using this item.

1. Decide on the height required (always use the lowest setting for the work in hand).
2. Ensure the claw-hook at the end of ratchet strap is positively engaged with the bottom hole on A-Frame upright.
3. Remove lower bolt on trap plate.
4. Tension ratchet strap to take the upright/beam weight.
5. Remove upper bolt on trap plate.
6. Operate ratchet to adjust height to required setting, ensuring that the bolt holes are aligned.



7. Re-insert upper bolt and nut/washer assembly.
8. Ease tensioned strap aside, and re-insert lower bolt and secure.
9. Repeat steps 2-8 on the second A-Frame, ensuring that both A-Frames finish at the same height (or do both in parallel with second person).
10. Check all bolts on the gantry are sufficiently secure by ensuring all spring washers are fully depressed.
11. If the hoist is not already attached to the suspension point on the trolley, do so now (using stepladder if height setting requires). If this is not safe, disassemble gantry and re-start from the scissoring operation of the Gantry Assembly Instructions – page 11, Step 9.

C) Medium or Small A-Frame with no gearing fitted:

Always wear gloves when using this item.

Adjust the upright position at one A-Frame (a 2 man operation – one on the bolts and one on the upright) by

removing 2 x upright securing bolts, moving the upright to the appropriate setting by lifting from the strut handle.

Re-secure with bolts, nuts and washers (do not over tighten).

Repeat the height adjustment at the opposite end.

N.B. Ensure the beam is horizontal prior to any lift.

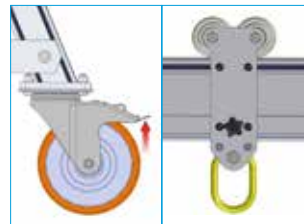

Release trolley brake and wheel brakes to position the PORTA-GANTRY directly over the lifting point.

VARIANTS AND OPTIONS

- Wind Up Jack Legs
- Ratchet Beam Elevation System
- Customised Configurations
- PORTA-GANTRY 500-3000
- PORTA-GANTRY RAPIDE

A-Frame and Stabiliser Leg



Fig 1.

Minimum Two Person Operation Recommended

The A-Frames of WLL 5000kg capacity need to be handled with care and respect. The centre of gravity is high on the intermediate (I) and tall (T) models and should have a stabiliser leg fitted. There are two safe modes of handling depending on the environment.

In the 'Stabiliser Leg' mode it is designed for use on flat, concrete or tarmac surfaces. This is the ideal mode for moving about in a factory or depot environment.

In the 'Wheelbarrow' mode it is designed for manoeuvring on rough ground and open areas with the centre of gravity of the A-Frame as low as possible.

Manoeuvring A-Frame using Stabilising Leg in Wheelbarrow Configuration

Two Person Operation Recommended



Always wear gloves when using this item.

1. With the A-Frame on its back, ensure that the A-Frame Castor Wheels are locked in position. Put brakes on only with protective footwear DO NOT USE HANDS.
2. Ensure that the Stabilising Leg is correctly and safely assembled in the Wheelbarrow configuration.
3. Ensure the pneumatic castor has its directional lock deployed.
4. Rotate the A-Frame onto its front so that the stabilising leg wheel is resting on the ground.
5. Using correct manual-handling procedures, two people lift the A-Frame from the tie-bar (one at Point A and one at Point B - as shown above).
6. Manoeuvre the A-Frame in the same way as a wheelbarrow.
7. When 'parking' an A-Frame in this mode always apply the castor brake.

No. 1 in lightweight, portable, safe lifting solutions

Manoeuvring A-Frame using Stabilising Leg in Vertical Configuration

One Person Operation Recommended for Manoeuvring.

Always wear gloves when using this item.

1. With the A-Frame on its back, ensure that the A-Frame Castor Wheels are locked in position. Put brakes on only with protective footwear DO NOT USE HANDS.
2. Ensure that the Stabilising Leg is correctly and safely assembled in the vertical configuration.
3. Lift the A-Frame into the vertical position (two person activity) about the A-Frame Castor Wheels and slowing down as the vertical point is reached and exceeded.
4. Continue to tilt the A-Frame past the vertical position until the Stabilising Leg Castor Wheel takes the weight of the A-Frame.
5. To manoeuvre the A-Frame ensure that the stabiliser castor has directional lock disengaged and release the brake on the A-Frame castors.

6. With the A-Frame weight resting on the 3 castors and all pins secured with clips, unlock the castor brakes and the A-Frame is easily manoeuvred by one person with one hand on the A-Frame leg and one hand on the stabilising leg strut - see Fig. 2.

7. When "parking" the A-Frame in this mode, always apply a minimum of 2 castor brakes.

N.B. Re: Tall and Intermediate (T & I) configurations:

The stabiliser leg has two settings – one for the T frame size and one for the I frame size, which will be at the correct setting for your gantry. However, if using the stabiliser on a different size 5000kg gantry (T or I) then adjustment can be carried out by moving the 2 bolts on the aluminium profile. Extended for the T, shortened for the I. Ensure it is set to suit the relevant frame size.

Changing Stabilising Leg from Wheelbarrow to Vertical Configuration

Two Person Operation is Recommended
Always wear gloves when using this item.

1. With the A-Frame on its back, unpin the Wishbone Tie Bar from the Stabilising Leg.



2. Then unpin the castor link plate from the A-Frame Strut, ensuring that the weight of the Stabilising Leg is held to help prevent the trapping of hands or fingers.

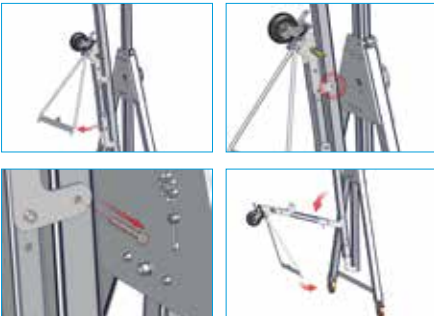

3. Pivot the Stabilising Leg about the Bolted Link Plate connection, and insert the Wishbone ends through the A-Frame Tie-Bar holes. Pin the Wishbone with the 2 pins.



No. 1 in lightweight, portable, safe lifting solutions

Changing Stabilising Leg from Vertical to Wheelbarrow Configuration

(Reverse of above)

Two Person Operation is Recommended

Always wear gloves when using this item.

1. With the A-Frame on its back, unpin the wishbone ends, and remove Wishbone ends from the Tie-Bar holes.
2. Pivot the Stabilising Leg about the Bolted Link Plate connection.
3. Pin the Castor Link Plate onto the A-Frame Strut, ensuring that the weight of the Stabilising Leg is held until securely pinned to help prevent the trapping of hands or fingers.
4. Pin the Wishbone Tie Bar onto the Stabilising Leg at both points.

WIND UP JACK LEG OPTION (WUJL)

WUJL option may be fitted to the gantry – if so this gives fine adjustment in the height setting (300mm total lift on the uprights) and gives independent foot adjustment, particularly useful on uneven ground. If the windup jack legs are fitted the following points must be observed:

1. Check whether the castors fitted are Load Rated (or Pneumatic). **N.B.** for pneumatic, non load bearing, castors the WUJL system must always be applied prior to performing any lift. If load rated castors are fitted the operator can choose whether the castors or WUJL take the load on each foot of the gantry.
2. When transporting over ground or manoeuvring the gantry, into position, always have the stands in the 'parked' position as in figure 1 or remove if required.
3. Position the gantry for the lift before setting the heights with the jack adjustment.
4. Before lifting ensure all jacks are in the correct lifting position and are secured with locking pins and clips as in figure 2.
5. Manually raise each leg/castor in turn and set the height by rotating jack handle clockwise.
6. Having set the adjustment of all four legs, stand back from the gantry and ensure that the gantry uprights are vertical and the beam is horizontal as in figure 3.
7. If the ground that the load spreading feet are on is soft and likely to sink when the load applied put boards under the feet to spread the load further.
8. Having performed the lifting operations, put the stands in the 'park' position and disassemble.



Fig.1 Wind Up Jack Leg in 'parked' position

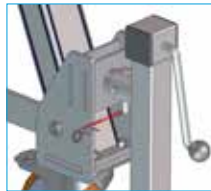

Fig.2 Jacks secured with locking pins and clips



Fig.3 Wind Up Jack Leg system in place – normally used with pneumatic "All Terrain Castors".

PORTA-GANTRY® 5000

No. 1 in lightweight, portable, safe lifting solutions

Customised Configurations

For customised systems additional assembly and operation information may be provided as required.

PORTA-GANTRY 500-3000

Unique lightweight, portable gantry system with WLL up to 3000kg.



See separate Assembly & Operating manual.

PORTA-GANTRY RAPIDE

Unique, ultra-lightweight, portable, rapid assembly gantry system with goods WLL up to 500kg designed for single person rapid deployment and operation and/or confined space/work at height applications and/or personnel lifting and fall protection up to 3 persons.



See separate Assembly & Operating manual.

E&OE

PORTA-GANTRY RANGE

Detailed Dimensions

Unique portable gantry system that can safely lift up to 5000kg, with manual assembly on just 4 bolts.

NOTE - beam height adjustment

The height of each gantry beam is easily adjusted by the release of 2 bolts on each upright and can be easily and safely raised into position by increments of 200 or 150mm depending on product.

To assist with this activity a Geared Wheel or Ratchet system is provided for the larger gantries; manual on smaller frames.

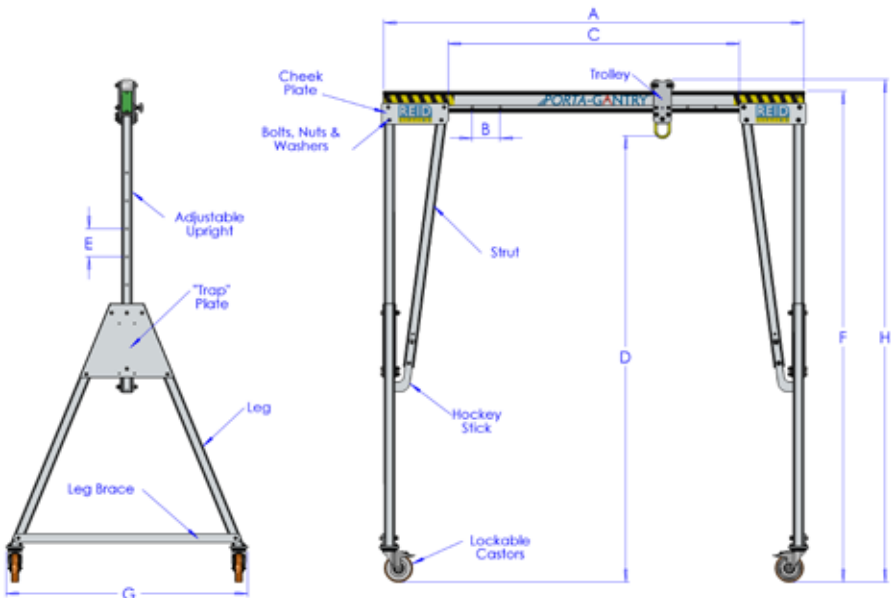

PORTA-GANTRY® 5000

No. 1 in lightweight, portable, safe lifting solutions

	Frame size	Dmax	E	Dmin	F	Hmax	Hmin	G	A-Frame Weight (kg)	Trolley Roller size	Custom Diam	
		Max height to lifting eye	Height increment	Min height to lifting eye	Max height to top of beam	Max height to top of roller	Min height to top of roller	Width				
WLL (kg)	500 / 1000	S	2355	5 x 150	1605	2675	2757	2007	1212	33	82	150
		M	2851	5 x 150	2101	3171	3253	2503	1429	40	82	150
		I	3188	5 x 200	2188	3499	3581	2581	1726	46	82	200
		T	4079	6 x 200	2879	4399	4481	3281	2011	51	82	200
		TC4	4527	6 x 200	3327	4847	4930	3730	2234	80	82	200
		TC3	5027	6 x 200	3827	5347	5430	4230	2557	82	82	200
		TC2	5527	8 x 200	3927	5848	5930	4330	2733	87	82	200
		TC1	5829	9 x 200	4029	6149	6231	4431	2733	95	82	200
WLL (kg)	2000	S	2355	5 x 150	1605	2675	2757	2007	1212	38	82	150
		M	2851	5 x 150	2101	3171	3253	2503	1429	40	82	150
		I	3188	5 x 200	2188	3499	3581	2581	1726	46	82	200
		T	4079	6 x 200	2879	4399	4481	3281	2011	51	82	200
		TC4	4527	6 x 200	3327	4847	4930	3730	2234	80	82	200
		TC3	5027	6 x 200	3827	5347	5430	4230	2557	82	82	200
		TC2	5527	8 x 200	3927	5848	5930	4330	2733	87	82	200
		TC1	5829	9 x 200	4029	6149	6231	4431	2733	95	82	200
WLL (kg)	3000	S	2410	5 x 150	1660	2730	2812	2062	1212	55	82	200
		M	2906	5 x 150	2156	3226	3308	2558	1429	60	82	200
		I	3188	5 x 200	2188	3499	3581	2581	1726	70	82	200
		T	4079	6 x 200	2879	4399	4481	3281	2011	82	82	200
		TC4	4527	6 x 200	3327	4847	4930	3730	2234	80	82	200
		TC3	5027	6 x 200	3827	5347	5430	4230	2557	82	82	200
		TC2	5527	8 x 200	3927	5848	5930	4330	2733	87	82	200
		TC1	5829	9 x 200	4029	6149	6231	4431	2733	95	82	200
WLL (kg)	5000	I	3181	5 x 200	2181	3592	3717	2717	1736	97*	125	200
		T	4049	6 x 200	2849	4487	4612	3412	2021	106*	125	200
S, M, TC3 & TC4 versions also available as custom systems												
WLL 5000 dims systems are shown using the deeper 'D' section beam												

All systems can be customised - Max height of lift (HoL) to 5800mm subject to WLL, and Min overall height for confined space.
 Dims use standard Master Link Trolley, other options available to increase resulting HoL and to assist with load movement.
 Beam Length Dim C = clear operating span = (A - 920mm)

* Weight includes stabiliser legs
 Beam lengths available up to 9000mm subject to WLL - for further information contact RED Lifting or our representatives.
 PORTA-GANTRY systems are fully EN795 Type B certified - please discuss requirements with RED.

		Standard Beam Length (mm)							
		2500	3000	3920	4570	5500	6000	8400	9000
WLL Rating (Kg)	500	19	22	29	34	41	44	62	66
	1000	19	22	29	34	41	44	79	84
	2000	19	22	29	34	52	93	130	X
	3000	19	22	37	43	85	93	130	X
	5000	39	47	61	71	85	X	X	X
Weight of Beams (kg)									

QUALITY & SAFETY



ACCREDITATIONS

Quality and Safety are key themes throughout this document and the REID Lifting ethos. It is with this in mind that we have undertaken external accreditations to ensure we stay focused on what is important to our clients and users and ahead of market trends and developments in Safety and Quality systems. REID Lifting has been successfully audited by Lloyds Register (LRQA) for approval of its Integrated Management System combining quality systems management, environmental issues and the Health and Safety practices within the company.

REID Lifting holds the following certifications:

- **ISO 9001** - Specifies requirements for a quality management system for any organisation that needs to demonstrate its ability to consistently provide product that meets customer and applicable regulatory requirements and aims to enhance customer satisfaction.
- **ISO 14001** - Specifies the requirements for implementing environmental management systems throughout all areas of the company.
- **OHSAS 18001** - Occupational Health and Safety Managements Systems.
- **LEEA Membership** - REID Lifting Ltd is a full member of the Lifting Equipment Engineers Association (membership 000897). REID Lifting conforms to the main aims of the Association which is to achieve the highest standards of quality and integrity in the operations of members. Their entry qualifications are demanding and strictly enforced through technical audits based on the Technical Requirements for Members.
- **IRATA Membership** - REID Lifting Ltd is an associate member of the Industrial Rope Access Trade Association (membership 148). All standard REID PORTA-GANTRY configurations meet the requirements of the International Code of Practice (ICOP) for industrial rope access.



Conformité Européenne (CE)

REID Lifting's products have been designed, tested and approved (as appropriate) by the Conformité Européenne. This certifies that REID Lifting's products meet the demands of the European Directives and regulations regarding Health and Safety requirements. The EC type-examination for this device has been carried out by SGS United Kingdom Ltd, 202b, Worle Parkway, Westonsuper-Mare, BS22 6WA, United Kingdom (CE body no.0120) in accordance with Module B of the PPE Regulation and EN 795:2012. The EC quality assurance system for this device has been carried out by Lloyd's Register Quality Assurance Limited, 1 Trinity Park, Bickenhill Lane, Birmingham, B37 7ES, United Kingdom (CE body no. 0088) in accordance with article Module D of the PPE Regulation.

The Queen's Award for Enterprise Innovation

REID Lifting has been awarded this prestigious award for innovative design and development of lightweight, portable and safe lifting solutions.

TESTING

Testing and Technical File review are integral parts of our design and manufacturing process – to externally verify the products, where appropriate, using government approved Notified Bodies. All REID Lifting products are type tested at laboratories that are accredited by the United Kingdom Accreditation Service (UKAS). In addition products are proof load tested either individually (or on a batch sampling basis). Full product design & development Technical Files are available for inspection.

PRODUCT IPR

Design Rights apply to all REID Lifting Ltd products, REID PATENTS in place or pending, for:

- *PORTA-GANTRY*
- *PORTA-GANTRY RAPIDE*
- *PORTA-DAVIT QUANTUM*
- *PORTA-DAVIT*
- *T-DAVIT*
- *SNAPPER*

All product names are Trade Marks of REID Lifting Ltd:

- *PORTA-GANTRY*
- *PORTA-GANTRY RAPIDE*
- *PORTA-DAVIT QUANTUM*
- *PORTA-DAVIT*
- *PORTA-BASE*
- *T-DAVIT*
- *PORTA-QUAD*
- *SNAPPER*
- *PORTA-LIFTER* Manhole Lifter

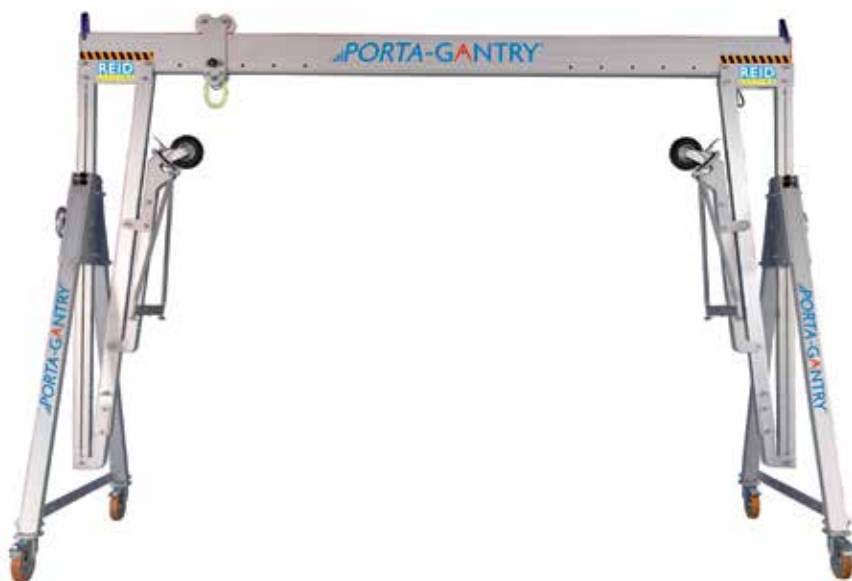



t +44 (0)1291 620796

e sales@reidlifting.com

w www.reidlifting.com

UK

REID Lifting
Unit 1 Wyview, Newhouse Farm Ind. Estate,
Chepstow, Monmouthshire, NP16 6UD, UK

t +44 (0)1291 620 796

f +44 (0)1291 626 490

e enquiries@reidlifting.com

w www.reidlifting.com

SWEDEN

2LIFT AB
C / O JJ-Group AB
Tryckarevägen 10
434 37 Kungsbacka SWEDEN

t +46 (0)7342 26155

e info.2lift@jjgruppen.se

w www.jjgruppen.se

FRANCE

REID Lifting France
P.A. de Kerboulard, Rue Gutenberg
56250 Saint-Nolf FRANCE

t +33 (0)297 53 32 99

f +33 (0)297 53 04 86

e contact@reidlifting.fr

w www.reidlifting.fr

AUSTRALIA

Vector Lifting
43 Spencer Street
Jandakot, WA 6164 AUSTRALIA

t +61 (0)8 9417 9128

f +61 (0)8 9417 4105

e info@vectorlifting.com.au

w www.vectorlifting.com.au

DE & AUT & CH

REID Lifting D-A-CH
Finkenstrasse 26
8280 Kreuzlingen SWITZERLAND

t +41 (0)71 686 90 40

f +41 (0)71 688 51 69

e jesser@reidlifting.de

w www.ecolistec.ch
www.reidlifting.de

USA & CANADA

Thern, Inc.
5712 Industrial Park Road
PO Box 347, Winona, MN 55987, USA

t +1 507 454 2996

f +1 507 454 5282

e info@thern.com

w www.thern.com

