



PORTA-GANTRY[®] RAPIDE

250-1000



ASSEMBLY VIDEO

Assembly & Operation

www.reidlifting.com



PORTA-GANTRY® RAPIDE 250-1000

No. 1 in lightweight, portable, safe lifting solutions

CONTENTS

INTRODUCTION

CORRECT OPERATION

- Intended Use
- Inspection Prior to Initial Operation
- Inspection Before Starting Work
- Maximum Capacity

NOTES FOR CORRECT USAGE

- Warning
- Attaching the Load
- Temperature Range
- Regulations

INSPECTION/MAINTENANCE

- Regular Inspections
- Maintenance/Repair
- Storage and Transportation
- Marking

ATEX

- ATEX - Classification
- ATEX - Identification
- ATEX - Spark Formation
- ATEX - Static Electricity
- ATEX - Inspection, Maintenance & Repair

IRATA

LANGUAGE

ASSEMBLY INSTRUCTIONS

- Pre-Assembly
- Standard Assembly
- Master-link/Close-Coupled Trolley Installation
- Height Adjustment
- Foot Adjustment
- Pre-Assembly
- Confined Space Assembly
- Gantry Stowage
- Trolley Storing
- Winch Bracket Installation
- Winch Installation
- Sheave Trolley Installation
- Beam Width Adjustment
- Changing the Foot Option
- Adjustable Foot Option

DIMENSIONS

- PORTA-GANTRY RAPIDE 250-500
- PORTA-GANTRY RAPIDE 1000

QUALITY & SAFETY

- Accreditations

TESTING

PRODUCT IPR

INSPECTION RECORD

INTRODUCTION

All users must read these operating instructions carefully prior to the initial operation. These instructions are intended to acquaint the user with the *PORTA-GANTRY RAPIDE* and enable him/her to use it to the full extent of its intended capabilities.

The operating instructions contain important information on how to handle the *PORTA-GANTRY RAPIDE* in a safe, correct and economic way. Acting in accordance with these instructions helps to avoid dangers, reduce repair costs and down time and to increase the reliability and lifetime of the *PORTA-GANTRY RAPIDE*.

Anyone involved in doing any of the following work with the gantry must read the operation instructions and act accordingly:

- Operation, including preparation, troubleshooting during operation and cleaning
- Maintenance, inspection, repair
- Transport

Apart from the operating guide, health & safety and accident prevention act valid for the respective country and area where the gantry frame is used, the commonly accepted regulations for safe and professional work must be adhered to.

It is incumbent on the user or instigator of work with the equipment that all users have suitable medical and physical capabilities. Likewise the competent person should ensure there is a rescue plan in place in the event of an emergency that could occur during the work.

N.B. This document should form an element of the overriding Risk Assessment and Method Statement required for each lift.

PORTA-GANTRY® RAPIDE 250-1000

No. 1 in lightweight, portable, safe lifting solutions

CORRECT OPERATION

Intended Use

The *PORTA-GANTRY RAPIDE* is intended to be used for the lifting of goods or the lifting of persons, or for providing a safety anchor for the prevention of falls.

N.B. We recommend that the device is dedicated to either goods or personnel use and where reasonably practicable to avoid using the structure for both.

*PORTA-GANTRY RAPIDE*s are suitable for Rope Access and have been tested to 15kN static load as per test requirements of IRATA International Code of Practice (ICOP).

Inspection Prior to Initial Operation

Each *PORTA-GANTRY RAPIDE* frame must be inspected prior to initial operation by a competent person. The inspection is visual and functional and shall establish that the structure is safe and has not been damaged by incorrect assembly, transport or storage. Inspections are instigated by the user.

Inspection Before Starting Work

The inspection procedure requires that a valid inspection/test certificate has been submitted to and checked by the user.

Before starting work inspect the gantry frame assembly and all load-bearing components for visual defects. Check the integrity of all profiles for denting and pin/bolt holes for wear and elongation.

Model	PGRS20		PGRS23, PGRM20, PGRM23		PGRS40, PGRM40, PGR20, PGR23, PGR40	
	WLL (kg)	Capacity [Persons]	WLL (kg)	Capacity [Persons]	WLL (kg)	Capacity [Persons]
Fall Arrest*	150	3	150	2	150	1
Personnel positioning limit	250		200		125	
Goods	500	N/A	400	N/A	250	N/A

Furthermore, test the trolley for free movement along the beam and check the operation of the footing option.

Ensure that the overall WLL limit is adhered to – following the necessary Risk Assessment and Method Statement.

Maximum Capacity

The *PORTA-GANTRY RAPIDE* is designed to lift and lower loads up to its rated capacity. The capacity indicated on the frame is the maximum Working Load Limit (WLL) or Safe Working Load (SWL) which must not be exceeded (definition is country dependent).

When being used as a personnel lifting anchor the user must use a body harness and retractable device or shock absorber to EN355, ANSI Z359.6-09 or CSA Z259.16-04 that limits the Maximum Allowed Force (M.A.F.) to 6kN. Winches used with the *PORTA-GANTRY RAPIDE* should comply to EN1496:2017 or equivalent.

Only ONE person/load may be attached to ONE trolley in accordance with the WLLs.

The *PORTA-GANTRY RAPIDE* has different ratings depending upon the application as detailed in the table below.

The gantry has an up-rated capacity for personnel positioning. This is when the structure is to be used as an anchor for lifting persons that have a suitably low chance of falling through a free distance and only carried out following a comprehensive risk assessment.

Model	PGR1TS20, PGR1TS30, PGR1TS40, PGR1TM20, PGR1TM30, PGR1TM40, PGR1TT20, PGR1TT30, PGR1TT40	
Application	WLL (kg)	Capacity [Persons]
Fall Arrest*	150	3
Personnel positioning limit	500	
Goods	1000	N/A

* N.B. only Applicable to *PORTA-GANTRY RAPIDE* systems being used in accordance with PD CEN/TS 16415:2013. When being used in accordance with EN795:2012, the structure shall be limited to a maximum of one user in fall arrest.

While the *PORTA-GANTRY RAPIDE* has the capacities stated below it is only one part of a fall arrest system which is only as strong as its lowest rated component. Each lift must be properly planned and all weights clearly known along with the WLLs and constraints of all fall arrest system devices.

The capabilities stated in the table below are only applicable to the standard *PORTA-GANTRY RAPIDE* configurations i.e. small, medium and tall. Bespoke versions of the *PORTA-GANTRY RAPIDE* are available tailored to specific lifting needs. If unsure about your system consult serial labels, information filled in on page 23 or consult your supplier. A custom *PORTA-GANTRY RAPIDE* is designated by a product number ending with a "C" found on the serial label attached to each A-frame and the beam. For custom designed *PORTA-GANTRY RAPIDE*s please contact your supplier for appropriate rating and capabilities.

In the event of simultaneous goods and personnel combined lifting or when being used as a fall arrest system in sub-zero AND wet conditions contact the supplier as capacities may be reduced.

NOTES FOR CORRECT USAGE

- We recommend the use of load-sensing or overload protection devices on all lifts
- The WLL (or SWL) rating must NOT be exceeded. Risk Assessment & Method Statement must consider additional loading in "wet lift" situations
- Ensure suitable winches and connection plates are used for all applications – see Winch Bracket Installation on pg 17
- Due care and attention should be practiced when transporting and storing gantry to avoid damage
- Assemble only as instructed (ensure all pins and bolts are present and fitted correctly as per instructions)
- We recommend that gloves should be worn when using this equipment
- We recommend single person assembly to avoid conflicting actions
- Set up the gantry at a safe distance from the hazard and subsequently move the structure into place

- The beam must be horizontal prior to any lift and A-frames vertical and parallel to each other
- Do not use the gantry frame if the trolley does not run freely along the beam
- Trolleys have the ability to be locked into position on the beam for certain applications. e.g. when gantry is used as a restraint point
- Attach hoist only to the lifting point on the trolley
- Avoid side pull. Lowering and lifting should only be carried out when the load chain/lifeline form a straight and vertical line between the load and lifting attachment point on the trolley
- Do not allow load to swing
- When lifting keep the load low to the ground
- **NEVER** walk away from structure whilst connected to the equipment i.e. connected by a fall arrest block or winch
- Only raise and lower loads when **CASTOR BRAKES** are **ENGAGED**
- When using the gantry as a fall arrest anchor the required clearance of the fall arrest device should be considered - refer to device Assembly & Operation manual and consider the height adjustment on the gantry
- Before the gantry is used consideration must be given to the potential effects of the lifelines over sharp edges, chemical reagents, electrical conductivity, cutting, abrasion, climatic exposure and the effect of offset forces as a result of pendulum falls
- The Gantry should **NOT** be moved under load except when a Competent Person or authority approves a Risk Assessment and a Method Statement for a particular reason

Warning

- The equipment shall not be used outside its limitations, or for any purpose other than that for which it is intended
- Only one lifeline should be used with each sheave and they should never cross paths with each other
- Do not lift or transport loads while personnel are in the danger zone

...PORTA-GANTRY® RAPIDE 250-1000

No. 1 in lightweight, portable, safe lifting solutions

- Do not allow personnel to pass under a suspended load
- When gantry is used with multiple persons attached working procedures should dictate that individual lifelines do not cross and become tangled
- It is **NOT** recommended to mix the use of the gantry with personnel and goods lifting concurrently
- **Never** leave a suspended load unattended
- Start moving the load along the beam only after it has been attached correctly and all personnel are clear of the danger zone
- Be aware of hazards when setting up/folding down, eg. hands/fingers trapped in rotating parts
- It is essential for safety that the *PORTA-GANTRY RAPIDE* is withdrawn from use immediately should:
 1. Any doubt arise about its condition for safe use
Or
 2. It has been used to arrest a fall and not be used again until confirmed in writing by a competent person that it is acceptable to do so
- Be aware of adverse weather, high, gusty or moderate/strong breeze conditions could impose horizontal loads, potentially affecting the stability of the structure. If weather conditions are impacting lifting operations, work should be stopped and gantry should be disassembled. If disassembling is not possible, the gantry should be tied to a rigid structure to avoid overturn
- When moving a loaded trolley along the beam, avoid sudden movements, move the load steadily and in a controlled manner
- Do **NOT** impact the gantry Frames with the load
- *RAPIDE* 1000 Tall systems (PGR1TTxx) are fitted with trolley stops on the beam. This is a safety feature and always **MUST** be in place before use. If beam length adjustment is required, ensure the stops have been repositioned accordingly

Attaching the Load

The operator must ensure that the hoist is attached in a manner that does not expose him or other personnel to danger by the hoist, chain(s) or the load.

Temperature Range

The *PORTA-GANTRY RAPIDE* can be operated in ambient dry temperatures between -20° and +55°C [-4°F to 131°F]. Consult your supplier in case of extreme working conditions. **If used in sub-zero and wet conditions, fall arrest appliances characteristics may change.**

Regulations

The *PORTA-GANTRY RAPIDE* complies with the following regulations:

PPE Regulation (EU) 2016/425, Machinery Directive 2006/42/EC, The Provision and Use of Work Equipment Regulations 1998 (S.I. 1998 No. 2306), The Lifting Operations and Lifting Equipment Regulations 1998 (S.I. 1998 No. 2307). The safety regulations of the respective country for using manual lifting equipment must be strictly adhered to. EN79:2012, ANSI Z359.18-2017 and CSA Z259.16-04 certified.

INSPECTION/MAINTENANCE Regular Inspections

To ensure that the gantry frame remains in safe working order it must be subjected to thorough periodic inspections by a competent person. Inspections are to be 6 monthly for personnel lifting and 12 monthly for goods only unless adverse working conditions or profile of use dictate shorter periods. The components of the gantry frame are to be inspected for damage, wear, corrosion or other irregularities. To check for worn parts it may be necessary to disassemble the gantry frame.

Repairs should only be carried out by an approved specialist workshop that uses original spare parts. It is recommended that once inspected the device is marked with the date of next inspection.

Inspections are instigated by the user. If detailed information is required on inspection and test criteria, please refer to your supplier's technical department.

Please refer to page 23 for the equipment Inspection Record.

If using the Gantry in explosive atmospheres see additional section titled ATEX.

Maintenance/Repair

In order to ensure correct operation not only the operations instructions, but also the conditions for inspection and maintenance must be complied with. If defects are found **stop** using the *PORTA-GANTRY RAPIDE* immediately.

No alterations or additions to the equipment should be made without the written consent of the manufacturer. Any repair shall only be carried out in accordance with the manufacturer's procedures.

It is recommended to maintain the equipment in a clean and dry manner. Cleaning is suggested using a sponge or cloth with warm, soapy water (using diluted domestic washing up liquid), rinsing and allowing to dry.

Storage and Transportation

When transporting the components the user must take note of the manual handling considerations.

Do not throw the gantry or its components down or stack items on top of it. Always place properly on the ground avoiding damage to the equipment.

Marking

The serial labels indicate:

- The product identification number
- The products unique serial number
- The goods WLL of the device
- The year of manufacture
- The standards to which the device is approved.
- The ATEX rating of the product (if applicable) - see ATEX section below
- CE 0088: Notified body number (currently LRQA) who are responsible for approving REID Lifting's quality control system



Read
Assembly & Operation instructions



PORTA-GANTRY RAPIDE
Assembly & Operation instructions

Equipment capacity warning label: refer to maximum capacity section for rating explanations.

PORTA-GANTRY RAPIDE 250-500

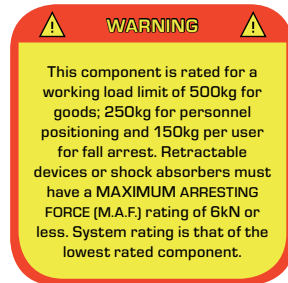

PORTA-GANTRY RAPIDE 1000

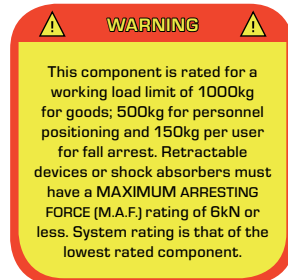

This product has been designed for use in explosive atmospheres. If the product is to be used in explosive atmospheres then the following section must be followed. Any different or exceeding use is considered incorrect and REID Lifting Ltd will not accept any responsibility for damages resulting from false application. The risk is solely with the user. If the product has been customised in any way then it may not comply with standards and not be suitable for use in explosive atmospheres. If this is the case then the product will not have any of the below marking. If in doubt contact your REID representative.

PORTA-GANTRY® RAPIDE 250-1000

No. 1 in lightweight, portable, safe lifting solutions

ATEX - Classification

As standard, the product meets the requirements of Category 3 equipment for use in Zone 2 explosive atmospheres, providing a normal level of protection where mixtures of air and gases, vapours or mists or by air/dusts mixtures are unlikely to occur or, if they do occur, are likely to do so only infrequently and for a short period only.

Or

Available as an upgrade the PORTA-GANTRY RAPIDE 500 can be supplied to meet the requirements of Category 2 equipment for use in Zone 1 explosive atmospheres, providing a high level of protection where mixtures of air and gases, vapours or mists or by air/dusts mixtures are likely to occur.

ATEX - Identification

In addition to the previous marking section the product will have the following identification on the serial label:

As Standard for Zone 2 Environments:

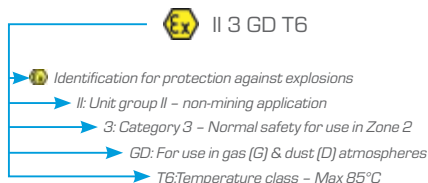

Or

As an Upgrade for use in Zone 1 Environments (PGR500 only):

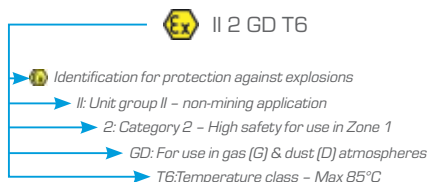

ATEX - Spark Formation

Increased danger of ignition may emanate from clashing of special material pairings. These are non corrosion-resistant steel or cast iron against aluminium, magnesium or pertinent alloys. This applies especially in case of rust or surface rust. When assembling the product and inserting fastening components they must be clear of rust and debris of any kind. Care must be taken to ensure the product is handled in a suitable manner, is never thrown and always placed onto the ground.

REID recommend the use of corrosion resistant tools when assembling the PORTA-GANTRY RAPIDE system to prevent the possibility of any sparks.

For ATEX Zone 1 use, stainless steel castor brackets are fitted to reduce the possibility of a spark.

ATEX - Static Electricity

For Zone 2 applications static electricity has been identified as potential for build up leading to an incendive spark. Although the risk of such ignition is unlikely the gantry must be earthed during assembly and use. This can be achieved by attaching a 4mm earthing lead to a convenient location on metallic parts of both the Gantry and Trolley.

In Zone 1 applications, for added explosion protection, the gantry is fitted with anti-static trolley rollers, stainless steel fasteners and therefore does not need to be earthed. However, the effectiveness of the conductivity during operation can be affected by a dirty tread or other environmental influences and therefore must be checked by the operator periodically.

ATEX - Inspection, Maintenance & Repair

If using the gantry in explosive atmospheres, in addition to the Regular Inspection/Maintenance information found on page 6, these additional instructions should be followed.

Inspections shall be instigated by the user prior to each use if used in a potentially explosive atmosphere. Inspections and maintenance shall be carried out at a safe distance away from an explosive atmosphere.

Special attention should be given to dust deposits on the structure, especially in areas where the profiles come into contact, and should be wiped clean and care taken not to apply materials that could create electrostatic charging. Additionally the bearings in the trolley rollers and castors should be checked to ensure they rotate freely.

The structure is predominantly constructed from aluminium which will not rust. However there are steel components used throughout. These are the fasteners, castors, master-link, trolley rollers, A-frame height adjustment gearing system (if fitted) and the height adjustment ratchet (if fitted). Where there is sign of any rust deposits on the aluminium structure it should be wiped clean as above and where there is sign of rust on a steel component then that component should be removed from use and the structure not used until a replacement is fitted.

IRATA



*PORTA-GANTRY RAPIDE*s are suitable for Rope Access and have been tested to 15KN static load as per test requirements of IRATA International Code of Practice (ICOP).

LANGUAGE

It is essential for the safety of the user that if this product is re-sold outside the original country of destination the reseller shall provide instructions for use, maintenance, for periodic examination and for repair in the language of the country in which the product is to be used.

..:PORTA-GANTRY® *RAPIDE* 250-1000

No. 1 in lightweight, portable, safe lifting solutions

ASSEMBLY INSTRUCTIONS

N.B. Appropriate PPE should be worn:



Gloves



Protective footwear



Hard hat

The *PORTA-GANTRY RAPIDE* and its constituent components are described in the image below.

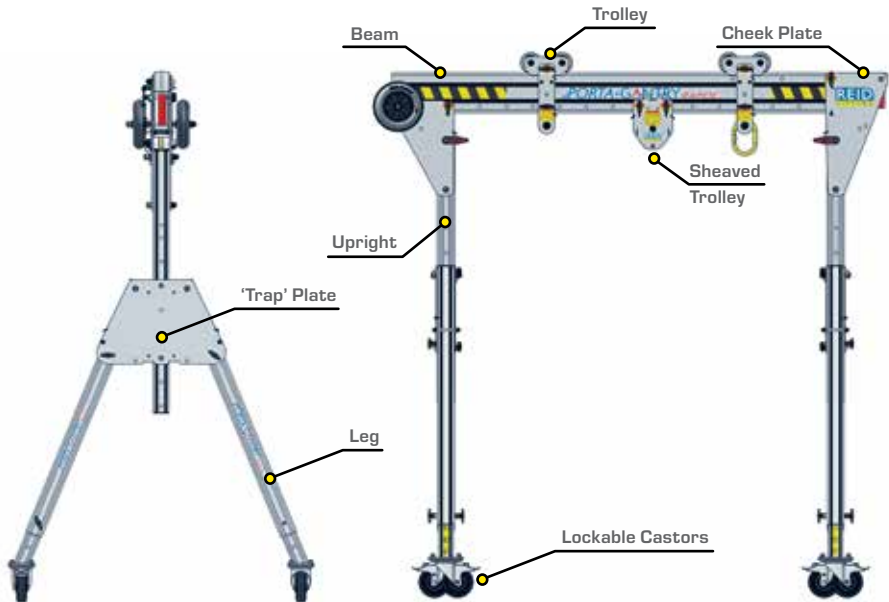

PRE-ASSEMBLY

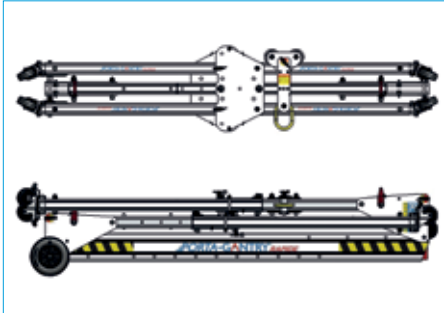

Pre set-up Checks

- *PORTA-GANTRY RAPIDE* system delivered flat packed
- Ensure castors are locked
- Allow sufficient clearance for gantry frame rotation. If sufficient space not available see steps 13 to 17 - Confined Space Set-up method

N.B. Trolley can be stored separately, on the upper Upright or the Leg

Standard Assembly



1. Rotate upper Upright to a vertical position.

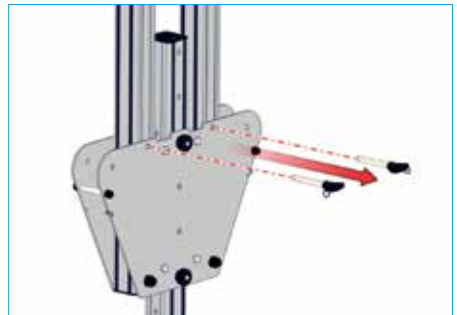

2. While in this vertical position remove ball lock pin from its stow hole on the Trap Plate.

...PORTA-GANTRY® RAPIDE 250-1000

No. 1 in lightweight, portable, safe lifting solutions



3. Open leg and insert ball-lock pin into second hole securing the leg in its open position. Repeat for second leg on the same Upright.

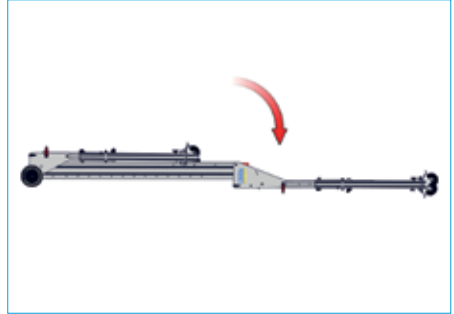

4. Continue rotation of upper Upright until it comes to rest on ground.

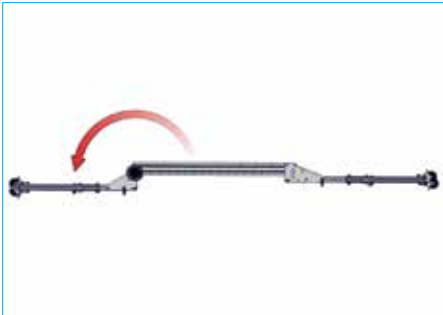

5. Repeat steps 1-4 for lower Upright.



6. Scissor upper Upright until ball-lock pin is adjacent to beam. Remove ball-lock pin and continue scissor motion until stops engage beam and holes are aligned.

Be careful not to trap hands between beam and cheek plates!



7. Re-insert ball-lock pin into hole ensuring the pin is fully engaged through hole. A gentle rocking motion can be used to induce alignment.



8. Repeat steps 6 and 7 for opposite Upright.



N.B. IF FITTED, ENSURE CASTOR BRAKES APPLIED BEFORE LIFTING A LOAD.

Master-link/Close-Coupled Trolley Installation

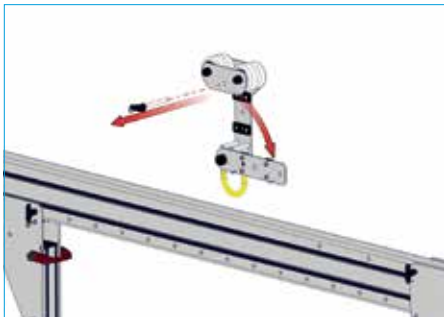

9. Remove pin. Open Trolley and present to beam with plate rotated through 90°.

Be careful not to allow plate to swing open uncontrolled.

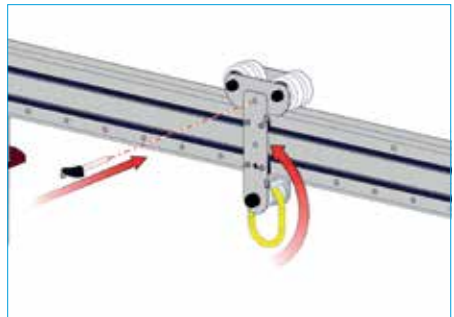

10. Close Trolley plate encapsulating the beam and re-insert ball-lock pin. Ensure pin is properly engaged through holes.

If Trolleys are required to be locked into position then an additional pin is available to provide Trolley lock-off.

..:PORTA-GANTRY® RAPIDE 250-1000

No. 1 in lightweight, portable, safe lifting solutions

Height Adjustment



11. Take weight of gantry Upright.
Remove bolts and adjust to the desired height.
Re-insert bolts and hand tighten quick release knobs ensuring the gantry is secure.

NB: Ensure upright is bolted using top and bottom fixing holes on Trap Plate.

NB: Never adjust the height while the gantry is under load.

Foot Adjustment



12. To increase height pull foot down until desired position is achieved.

NB: Never adjust the height while the gantry is under load.

Pre-lift Checks

- Ensure all ball lock pins are fully engaged into their respective holes
- Ensure all quick release knob/bolts on Trap Plates and Beam are hand tight and secure
- Ensure Upright is bolted using top and bottom fixing holes on Trap Plate.
- Ensure gantry is level

Confined Space Assembly



13. Rotate upper Upright to vertical position.

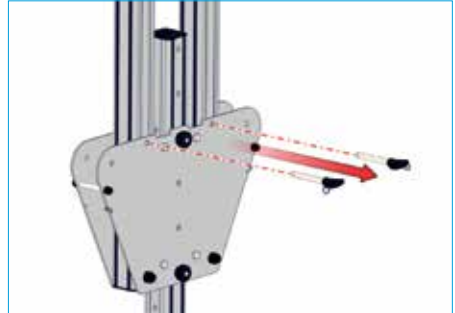

14. While in this vertical position remove ball lock pin from its stow hole.



15. Open leg and insert ball-lock pin into second hole securing the leg in its open position. Repeat for second leg.



16. Rotate upper Upright around until ball-lock pin is adjacent to beam. Remove pin and continue motion until stops engage beam and holes are aligned, as in steps 6 and 7.

Be careful not to trap hands between beam and cheek plates!

..:PORTA-GANTRY® RAPIDE 250-1000

No. 1 in lightweight, portable, safe lifting solutions



17. Repeat steps 13 to 16 for lower Upright.

Be careful not to trap hands between beam and cheek plates!

Gantry Stowage



18. To fold the gantry reverse steps 10 to 1 for Standard assembly or steps 17 to 13 for Confined Space assembly.

When folding gantry ensure ball-lock pins are stowed in cheek plate holes to avoid damage.

Pre-lift Checks

- Ensure all ball lock pins are fully engaged into their respective holes
- Ensure all quick release knob/bolts on Trap Plates and Beam are hand tight and secure
- Ensure Upright is bolted using top and bottom fixing holes on Trap Plate.
- Ensure gantry is level

Trolley Storing

Trolley can be stored separately, on the upper Upright or the Leg

Winch Bracket Installation

Never install winch bracket while gantry is under load. Only install winches which are approved by REID for use with the *PORTA-GANTRY RAPIDE* and a suitable interface / mounting plate supplied.

Winch can be installed on both sides of gantry and on either bolts A and B or B and C (PGR250-500) OR A and B, B and C or A and D (PGR1000). Ensure winch bracket and quick release knobs are hand tight.

PGR250-500

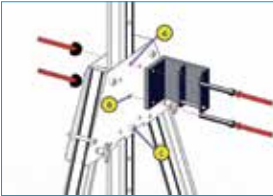

PGR1000

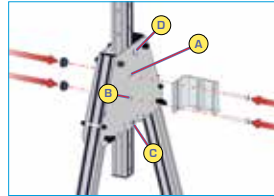

- Remove existing bolt, A or C.
Present bracket to gantry as shown (with locating pin at bottom) and insert new, longer bolts securing the winch with the quick release knobs provided.

Winch Installation

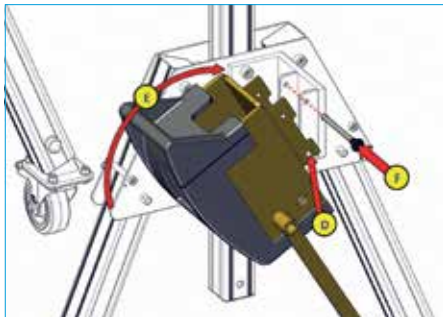

- Place winch onto locating pin, D.
Rotate winch to align holes, E.
Place retaining pin into holes, F.
Observe pin is securely engaged.

N.B. Illustration shows one example of many winches, fall arrests and interface brackets available.

Sheave Trolley Installation



- Thread rope through Cheek Plates and capture rope between Sheave and Beam.
Secure Sheave with ball-lock pin.
Observe pin is securely engaged.

..PORTA-GANTRY® RAPIDE 250-1000

No. 1 in lightweight, portable, safe lifting solutions

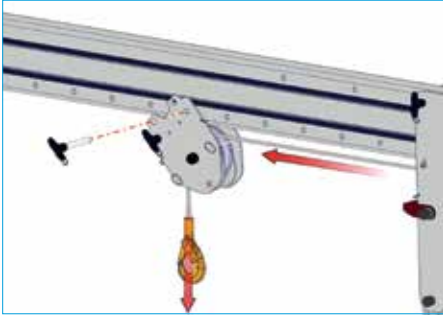

22. Present Sheaved Trolley to underside of Beam.
Capture rope between Sheaved Trolley and Beam
and insert pin as shown.

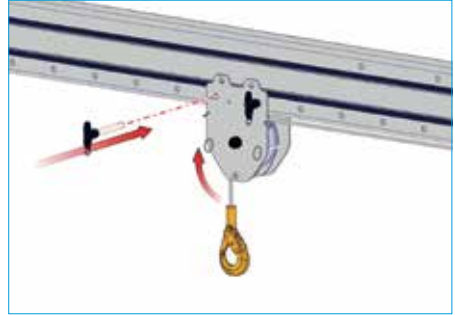

23. Insert second pin as shown
Observe both pins are fully engaged

Beam Width Adjustment

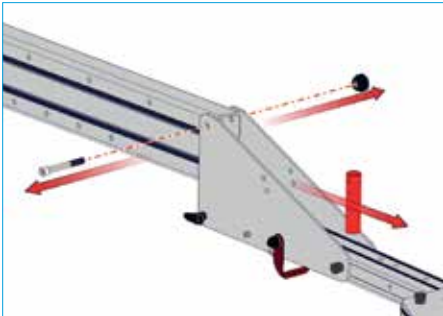

24. Remove bolt and handle.
Store handle in safe place.

NB: Beam width adjustment can take place
during steps 4 or 5.



25. Move Upright assembly to required position.
Re-insert bolt and hand tighten quick release
knob. Complete assembly of gantry as steps 6-8.

Changing the Foot Option



26. The foot option can be changed by removing the ball lock pin and withdrawing the foot cartridge assembly.

Adjustable Foot Option



27. For coarse adjustment in leg height set cartridge at desired point (2x50mm increments).



28. For fine height adjustment depress lever and push foot up to desired position. Observe gantry is level.

NB: Never adjust the height while the gantry is under load.

Pre-lift Checks

- Ensure all ball lock pins are fully engaged into their respective holes
- Ensure all quick release knob/bolts on Trap Plates and Beam are hand tight and secure
- Ensure Upright is bolted using top and bottom fixing holes on Trap Plate.
- Ensure gantry is level

..:PORTA-GANTRY® RAPIDE 250-1000

No. 1 in lightweight, portable, safe lifting solutions

DIMENSIONS

PORTA-GANTRY RAPIDE 250-500

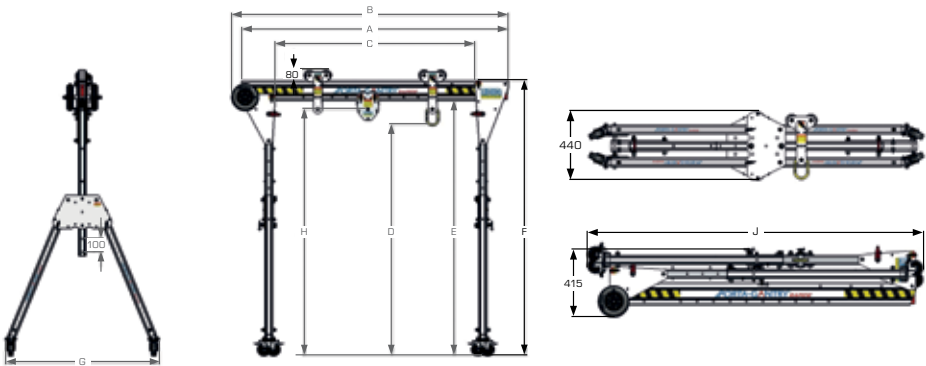

	Dimensions [mm]														WLL			Unit Weight			
	A Beam Length	B	C Min	C Max	D Min	D Max	E Min	E Max	F Min	F Max	G	H Min	H Max	J	Goods Capacity (kg)	Fall Arrest Capacity** No of Person(s)	Personnel Positioning** (kg)	(kg)			
PGRS20	2000	2076	1100	1500	1738	1938	1914	2114	2064	2264	1158	1850	2050	2190	500	3	250	33			
PGRS23	2300	2376	1200	1800										2376	400	2	200	35			
PGRS40	4000	4076	2700	3500										4076	250	1	125	40			
PGRM20	2000	2076	1100	1500	1642	2042	1818	2218	1968	2368	1215	1755	2155	2076	400	2	200	35			
PGRM23	2300	2376	1200	1800										2376				400	2	200	36
PGRM40	4000	4076	2700	3500										4076				400	2	200	41
PGR20	2000	2076	1100	1500	1916	2816	2092	2992	2342	3142	1586	2028	2928	2631	250	1	125	39			
PGR23	2300	2376	1200	1800										2631				400	2	200	40
PGR40	4000	4076	2700	3500										4076				400	2	200	45

**Ratings using European standards. Contact REID for other standards.

PORTA-GANTRY RAPIDE 1000

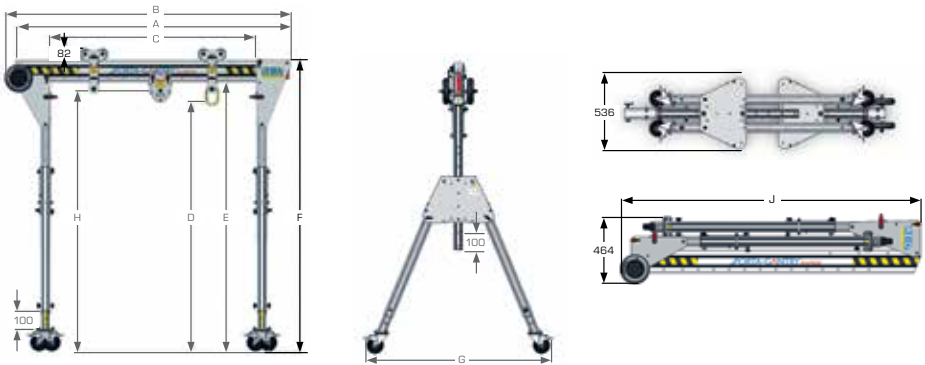

	Dimensions (mm)													WLL			Unit Weight (kg)	
	A	B	C _{Min}	C _{Max}	D _{Min}	D _{Max}	E _{Min}	E _{Max}	F _{Min}	F _{Max}	G	H _{Min}	H _{Max}	J	Goods Capacity (kg)	Fall Arrest Capacity** No of Person(s)		Personnel Positioning** (kg)
PGR1TS20	2000	2077	1102	1502	1430	1930	1661	2161	1822	2322	1270	1549	2049	2077	1000	3	500	45
PGR1TS30	3000	3077	1902	2502										3077	1000	3	500	53
PGR1TS40	4000	4077	1902	3502										4077	1000	3	500	58
PGR1TM20	2000	2077	1102	1502	1740	2440	1900	2600	2061	2761	1484	1859	2558	2200	1000	3	500	49
PGR1TM30	3000	3077	1902	2502										3077	1000	3	500	54
PGR1TM40	4000	4077	1902	3502										4077	1000	3	500	59
PGR1TT20*	2000	2077	598	1050	1980	2880	2140	3040	2301	3201	1698	2099	2999	2630	1000	3	500	53
PGR1TT30*	3000	3077	1417	2017										3077	1000	3	500	58
PGR1TT40*	4000	4077	2385	2985										4077	1000	3	500	62

*Trolley stops fitted to beam

**Ratings using European standards. Contact REID for other standards.

QUALITY & SAFETY

ACCREDITATIONS

Quality and safety are key themes throughout this document and the REID Lifting ethos. It is with this in mind that we have undertaken external accreditations to ensure we stay focused on what is important to our clients and users, and ahead of market trends and developments.

REID Lifting is continuously audited by Lloyds Register Quality Assurance (LRQA) (CE body no. 0088) for approval of its Integrated Management System combining quality systems management, environmental issues and the health and safety practices within the company.

- **ISO 9001:2015** - Specifies requirements for a quality management system for any organisation that needs to demonstrate its ability to consistently provide products that meet customer and applicable regulatory requirements and aims to enhance customer satisfaction
- **ISO 14001:2015** - Specifies the requirements for implementing environmental management systems throughout all areas of the company
- **OHSAS 18001:2007** - Occupational health and safety management system
- **LEEA Membership** - REID Lifting is a full member of the Lifting Equipment Engineers Association (LEEA membership 000897). REID Lifting conforms to the main aims of the association which is to achieve the highest standards of quality and integrity in the operations of members. Entry qualifications are demanding and strictly enforced through technical audits based on the Technical Requirements for Members
- **IRATA** - REID Lifting is an associate member of the Industrial Rope Access Trade Association (IRATA International membership number 148). REID Lifting works in accordance with the IRATA Code of Practice, by doing so, contributes to promote the development of safe systems



Conformité Européenne (CE)

REID Lifting's products have been designed, tested and approved (as appropriate) by the Conformité Européenne. This certifies that REID Lifting's products meet the demands of the European Directives and Regulations regarding health and safety requirements. The EC type-examination for this device has been carried out by SGS United Kingdom Ltd, 202b, Worle Parkway, Weston-super-Mare, BS22 6WA, United Kingdom (CE body no.0120) in accordance with Module B of the PPE Regulation. The EC quality assurance system for this device has been carried out by Lloyd's Register Quality Assurance Limited, 1, Trinity Park, Bickenhill Lane, Birmingham B37 7ES, United Kingdom (CE body no. 0088) in accordance with Module D PPE Regulation (EU) 2016/425.

The Queen's Award for Enterprise

REID Lifting has been awarded this prestigious award on four occasions for design, development and sale of lightweight, portable and safe lifting solutions.



- Innovation category 2006 and 2013
- International Trade 2013 and 2018

TESTING

Testing and Technical File review are integral parts of our design and manufacturing process. External verification of products is undertaken where appropriate, using government approved Notified Bodies.

All products have been thoroughly type tested at UKAS accredited laboratories. Each system is supplied with a certificate of conformance and individual record of thorough examination or test.

Full product design and development Technical Files are available for inspection.

PRODUCT IPR

Intellectual property rights apply to all REID Lifting Ltd products. **There are patents in place, or pending, for:**

PORTA-GANTRY | PORTA-GANTRY RAPIDE | PORTA-DAVIT QUANTUM | T-DAVIT

All product names are trade-marks of REID Lifting Ltd:

PORTA-GANTRY | PORTA-GANTRY RAPIDE | PORTA-DAVIT | PORTA-BASE | T-DAVIT | PORTA-GUAD

E&OE

INSPECTION



INSPECTION RECORD

 Unit 1 Wynewick, Newhouse Farm Industrial Estate,
 Chepstow, Monmouthshire, NP18 6UD, UK
 www.reidlifting.com +44 (0)1291 620 796

Product No.: xxxxxxxx **A**
 Serial Number: xxx xxx xxxxxx **B**
 WLL: xxxxx kg GOODS **C**
 Year of Manufacture: 20xx **D**
 Standards: EN795:2012*
 ATEX: II 3 GD T6 

*For max. 150kg fall arrest, single person use
CE 0088 

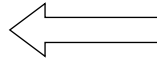

* Insert data from serial numbers found on product into table below

Product number(s)* A			
Serial number(s)* B			
WLL* C			
Year of manufacture* D			
Name of user			
Date of purchase			
Date of first use			
Periodic Examination and Repair History			
Date	Inspected by	Pass/Fail	Comments



 +44 (0)1291 620796

 sales@reidlifting.com

 www.reidlifting.com



UK

REID Lifting
Unit 1 Wyview, Newhouse Farm Ind. Estate,
Chepstow, Monmouthshire, NP16 6UD, UK

 +44 (0)1291 620 796
 +44 (0)1291 626 490
 enquiries@reidlifting.com
 www.reidlifting.com



SWEDEN

2LIFT AB
C / O JJ-Group AB
Tryckarevägen 10
434 37 Kungsbacka SWEDEN

 +46 (0)7342 26155
 info.2lift@jjgruppen.se
 www.jjgruppen.se

ITALY

F.A.S. S.p.A.
Via dei Lavoratori 118/120
20092 Cinisello Balsamo ITALY

 +39 (0)2612 4951
 s.scarpetta@fasitaly.com
 www.fasitaly.com

USA

Thern, Inc.
5712 Industrial Park Road
PO Box 347, Winona, MN 55987, USA

 +1 507 454 2996
 +1 507 454 5282
 info@thern.com
 www.thern.com

FRANCE

REID Lifting France
P.A. de Kerboulard, Rue Gutenberg
56250 Saint-Nolf FRANCE

 +33 (0)297 53 32 99
 +33 (0)297 53 04 86
 contact@reidlifting.fr
 www.reidlifting.fr

DE & AUT & CH

REID Lifting D-A-CH
Finkenstrasse 26
8280 Kreuzlingen SWITZERLAND

 +41 (0)71 686 90 40
 +41 (0)71 688 51 69
 jesser@reidlifting.de
 www.ecolistec.ch
 www.reidlifting.de

AUSTRALIA

Vector Lifting
43 Spencer Street
Jandakot, WA 6164 AUSTRALIA

 +61 (0)8 9417 9128
 +61 (0)8 9417 4105
 info@vectorlifting.com.au
 www.vectorlifting.com.au

CANADA

Equipment Corps Inc.
1256 Arvin Avenue, Stoney Creek
On L8E 0H7 CANADA

 +1 905 545 1234
 +1 905 545 1270
 sales@equipmentcorps.com
 www.equipmentcorps.com

