

# T-DAVIT®



PORTA-GANTRY



PORTA-GANTRY RAPIDE



PORTA-DAVIT



T-DAVIT



WEBSITE

## Assembly & Operation

[www.reidlifting.com](http://www.reidlifting.com)



## CONTENTS

### INTRODUCTION

### CORRECT OPERATION

- Intended use
- Inspection prior to initial operation
- Inspection before starting work
- Maximum capacity
- Notes for correct usage
- Warning
- Attaching the load
- Temperature range
- Regulations
- Inspection/Maintenance
- Storage and transportation
- Sockets
- Marking
- Language

### ASSEMBLY INSTRUCTIONS

### QUALITY & SAFETY

## INTRODUCTION

All users must read these operating instructions carefully prior to the initial operation. These instructions are intended to acquaint the user with the *T-DAVIT* and enable him/her to use it to the full extent of its intended capabilities.

The operating instructions contain important information on how to handle the *T-DAVIT* in a safe, correct and economic manner. Acting in accordance with these instructions helps to avoid dangers, reduce repair costs and down time and to increase reliability and lifetime of the davit.

Anyone involved in doing any of the following work with the *T-DAVIT* must read the operation instructions and act accordingly:

- operation, including preparation, trouble shooting during operation and cleaning
- maintenance, inspection, repair
- transport

Apart from the operating guide, health & safety and accident prevention act valid for the respective country and area where the equipment is used, the commonly accepted regulations for safe and professional work must be adhered to.

It is incumbent on the user or instigator of work with the equipment that all users have suitable medical and physical capabilities. Likewise the competent person should ensure there is a rescue plan in place in the event of an emergency that could occur during the work.

N.B. This document should form an element of the overriding Risk Assessment and Method Statement required for each lift.

## No. 1 in lightweight, portable, safe lifting solutions

### CORRECT OPERATION

#### Intended for use

The T-DAVIT range is intended to be used for the lifting of goods, the lifting of persons or for providing a safety anchor for the prevention of falls.

**NOTE: Not all T-DAVITs are certified for the lifting of personnel! If unsure whether your product is designed for the lifting of persons consult your serial label, see Marking, or Certificate of Test which will indicate the WLL for persons if applicable.**

#### Inspection prior to operation

Each T-DAVIT must be inspected prior to initial operation by a competent person. The inspection is visual and functional and shall establish that the structure is safe and has not been damaged by incorrect assembly, transport or storage. The inspection should particularly concentrate on:

- dents or indentations on the kingpin, beam and column surfaces;
- straightness of beam and column sections;
- elongation of the beam holes or signs that beam inserts have become loose;
- the condition of the beam clevis pins for damage and straightness;
- damage to the attachments.

Inspections are instigated by the user.

#### Inspection before starting work

The inspection procedure requires that a valid inspection/test certificate has been submitted to and checked by the user.

Before starting work inspect the assembly and all load-bearing components for visual defects.

Check the integrity of all profiles for denting and bolt holes for wear and elongation. Ensure that the overall working load limit (WLL) is adhered to – following the necessary Risk Assessment and Method Statement.

#### Maximum capacity

The T-DAVIT is designed to lift and lower loads up to its rated capacity. The capacity indicated on the product is the maximum working load limit (WLL) or safe working load (SWL) which must not be exceeded (definition is country dependent).

When being used as a personnel lifting anchor the user must use a body harness and retractable device or shock absorber that complies with EN355, ANSI Z359.6-09 or CSA Z259.16-04 (whichever is relevant) that limits the maximum allowed force (M.A.F.) to 6kN Winches used with the T-DAVIT should comply to EN1496:2006 or equivalent.

Only ONE person/load may be attached to the T-Davit structure in accordance with the WLL's.

If the T-DAVIT is to be used for personnel winching the WLLs must be observed. It is possible for the T-DAVIT to have a WLL higher than that could be used with a fall arrest device. This is for situations where the structure is to be used as an anchor for lifting persons that have **no possibility of falling through a free distance** or when drafting out a rescue plan and should only be carried out following a comprehensive risk assessment.

**Note: If winching a secondary line/fall arrest unit may also be required.**

While the T-DAVIT will have the capabilities stated on the product it is only one part of a fall arrest system which is only as strong as its lowest rated component. Each lift must be properly planned and all weights clearly known along with the WLL's and constraints of all fall arrest system devices.

In the event of simultaneous goods and personnel combined lifting or when being used as a fall arrest system in sub-zero AND wet conditions contact the supplier as capacities may be reduced.

## Notes for correct usage

- We recommend the use of load-sensing or overload protection devices on all lifts.
- The risk assessment & method statement must consider additional loading resulting from any “wet lift” or ‘break-out force’ situations.
- Ensure suitable winches and connection plates are used for all applications.
- Due care and attention should be practiced when transporting and storing the product to avoid damage.
- Do not throw the product or its components down or stack items on top of it. Always place properly on the ground to avoid damaging the equipment.
- Assemble only as instructed (ensure all bolts are present and fitted correctly as per instructions).
- We recommend that gloves should be worn when using this equipment.
- Set up the product in its mounting socket ensuring that it is a safe location and there is no risk of falling into the hazard.
- Persons are forbidden to walk or stand in dangerous areas.
- Attach the load only to the lifting points on the beam or the lifeline/winch-line.
- Do not allow the load to swing.
- When lifting keep the load as low to the ground as possible.
- If the T-DAVIT is to be used in special atmospheres contact your supplier.
- When using the T-DAVIT as a fall arrest anchor the required clearance of the fall arrest device should

be considered - refer to the device’s Operations and Maintenance.

- NEVER walk away from structure whilst still attached to the equipment.
- Before the T-DAVIT is used consideration must be given to the potential effects of the ropes running over sharp edges, chemical reagents, electrical conductivity, cutting, abrasion, climatic exposure and the effect of offset forces as a result of pendulum falls.

## Disclaimer



All REID Lifting sockets & extensions have been designed, developed and tested for safe use with REID equipment and form a key part of the integrity of the total system.

- All sockets have a working load limit (WLL) based on the maximum radius setting of the davit, and the socket installation and verification tests performed.
- All sockets are supplied in galvanised mild steel or stainless steel (316L grade, passivated).
- Sockets can be powder coated upon request e.g. Yellow for trip hazard warning.

Should non-standard third party sockets be used, REID Lifting’s Declaration of Conformity & Incorporation on the products is negated. i.e. The system becomes the responsibility of the client.

## Warning

- The equipment shall not be used outside its limitations, or for any purpose other than that for which it is intended.
- Do not allow personnel to pass under a suspended load.

## No. 1 in lightweight, portable, safe lifting solutions

- NEVER leave a suspended load unattended.
- The T-DAVIT can only be used for lifting **or** arresting the fall of ONE person.
- It is NOT recommended to mix the use of the T-DAVIT with personnel and goods lifting concurrently.
- Be aware of hazards when setting up/setting down.
- It is essential for safety that the T-DAVIT is withdrawn from use immediately should:
  1. any doubt arise about its condition for safe use or;
  2. it has been used to arrest a fall

and not be used again until confirmed in writing by a competent person that it is acceptable to do so.

### Attaching the load

The operator must ensure that the load is attached in a manner that does not expose him or other personnel to danger by the hoist, chain(s) or the load.

### Temperature range

The T-DAVIT can be operated in ambient dry temperatures between -20° and +55°C (-4°F to 131°F). Consult your supplier in case of extreme working conditions.

**If used in sub-zero and wet conditions, the performance may be affected.**

### Regulations

The T-DAVIT complies with the following regulations:

PPE Directive 89/686/EEC, Machinery Directive 2006/42/EC, The Provision and Use of Work Equipment Regulations 1998 (S.I. 1998 No. 2306), The Lifting Operations and Lifting Equipment Regulations 1998 (S.I. 1998 No. 2307). The safety regulations of the respective country for using manual lifting equipment must be strictly adhered to. EN795:2012 compliant.

## INSPECTION/MAINTENANCE

### Regular inspections

To ensure that the structure remains in safe working order it must be subjected to thorough periodic

inspections by a competent person. Inspections are to be 6 monthly if used for the lifting of persons or 12 monthly otherwise unless adverse working conditions or profile of use dictate shorter periods. The components of the structure are to be inspected for damage, wear, corrosion or other irregularities. To check for worn parts it may be necessary to disassemble the structure. Particular attention should be paid to the areas of the structure described under INSPECTION PRIOR TO OPERATION.

Repairs should only be carried out by an approved specialist workshop that uses original spare parts.

**Inspections are instigated by the user. If detailed information is required on inspection and test criteria, please refer to your supplier's technical department.**

### Maintenance/Repair

In order to ensure correct operation, not only the operating instructions, but also the conditions for inspection and maintenance must be complied with. If defects are found **stop** using the T-DAVIT immediately.

No alterations or additions to the equipment should be made without the written consent of the manufacturer. Any repair shall only be carried out in accordance with the manufacturer's procedures.

It is recommended to maintain the equipment in a clean and dry manner. Cleaning is suggested using a sponge or cloth with warm, soapy water (using diluted domestic washing up liquid), rinsing and allowing to dry.

### Storage and transportation

The T-DAVIT and its accessories are to be stored and transported in the bags provided.

When transporting the components the user must take note of the manual handling considerations.

## SOCKETS

The T-DAVIT structure needs to be anchored to a surface for use and to do this it can be supplied with one of the mounts specified below (only mounts supplied by

REID Lifting are approved to be used with the T-DAVIT):

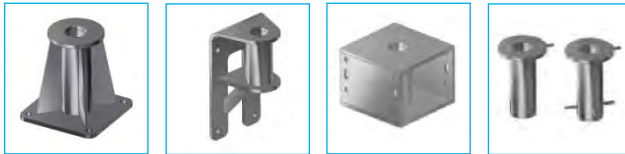

Top Mount

Side Mount

Bridge Mount

Cast & Resin Bonded

- The **top mount** is for use of flat horizontal surfaces. It can be installed onto concrete using resin bonded anchors or into steel work using bolts.
- The **side mount** can be installed using resin bonded anchors or mechanical anchors.
- The **bridge mount socket** for mounting in steel work.
- The **cast and resin bonded sockets** can be cast in or resin bonded.

## Verifying the installation

REID Lifting recommends testing the installation of the socket before use; especially when using resin bonded anchors.

When verifying the installation we recommend that it is tested to a maximum force of 6kN at the devices maximum radius if used for the lifting of personnel. If only used for the lifting of goods we recommend testing to no greater than 125% of the goods WLL at its maximum radius. All tests should be carried out in all anticipated worst case loading directions, sustained for a duration of 3 minutes.

If unable to test the installation as a whole then each anchor can be isolated and tested individually applying the applicable loading, i.e. tension and/or shear loads. For clarification on the loads contact your equipment supplier.

If an installation differs from the mounts referred to above or to that specified by your supplier then the competent person must verify by calculation that the installation can withstand:

- for personnel, 12kN at the devices maximum radius in all anticipated worst case loading directions but not test to more than 6kN at the devices maximum radius;

- for lifting of goods, 150% of the goods WLL at the devices maximum radius in all anticipated worst case loading directions but not test to more than 125% of the goods WLL at the devices maximum radius.

If required a sacrificial anchor may need to be installed to verify the installation has the ultimate capacities required.

## MARKING

The serial labels indicate:

- The product description.
- The product identification number.
- The products unique serial number.
- The goods working load limit (WLL) of the device.
- The year of manufacture.
- The standards to which the device is approved **(Only applicable when rated for the lifting of persons)**.
- CE 0088: CE mark plus notified body number (currently LRQA) who are responsible for monitoring REID Lifting's quality control system in accordance with Article 11B of the PPE Directive **(Only applicable when rated for the lifting of persons otherwise CE just stated)**.

## LANGUAGE

It is essential for the safety of the user that if this product is re-sold outside the original country of destination the reseller shall provide instructions for use, maintenance, for periodic examination and for repair in the language of the country in which the product is to be used.



Read the Assembly & Operation instructions.



T-DAVIT  
 Assembly & Operation instructions.

No. 1 in lightweight, portable, safe lifting solutions

## ASSEMBLY INSTRUCTIONS

**N.B. Appropriate PPE should be worn • Gloves • Protective footwear • Hard hat**

The T-DAVIT and its constituent components are described in the image below. The use of a socket extension is optional and the mount type may vary between a top mount, side mount, cast in or resin bonded depending on application. The T-DAVIT shown is a winched version but a variant is also available that is un-winched.





## Assembling the T-DAVIT



1. Insert the T-DAVIT into the socket as shown.

**N.B. Top mount socket shown.**

**N.B. If using a socket extension, install first.**

## Assembling the beam

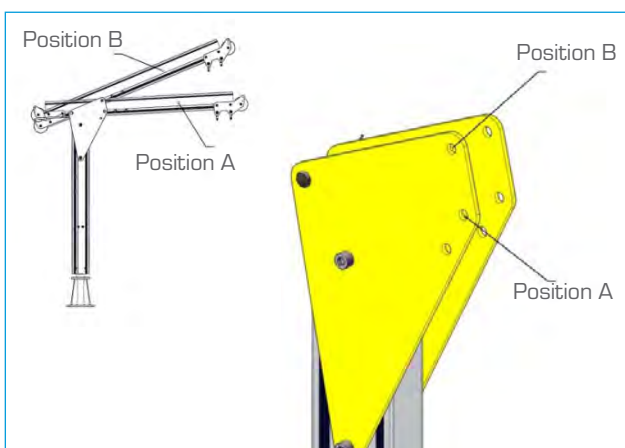

2. The T-DAVIT beam can be assembled at 2 positions as shown. Ensure the correct set-up chosen at this stage.

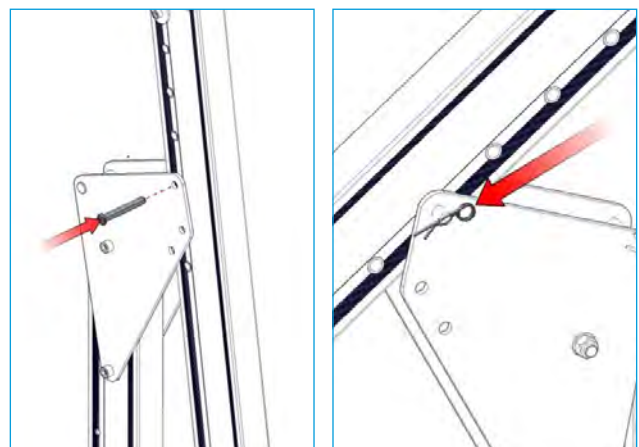

3. Present the beam to the chosen location and insert the clevis pin. **Secure the pin with retaining Rclip.**

**N.B. If a socket extension is being used the use of a ladder may be required.**

No. 1 in lightweight, portable, safe lifting solutions

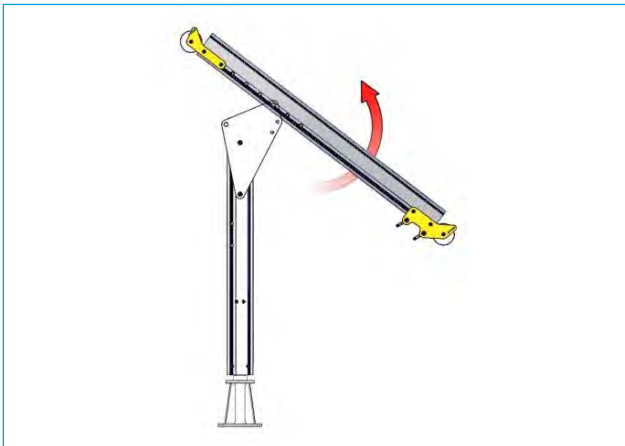

4. Rotate the beam as illustrated.

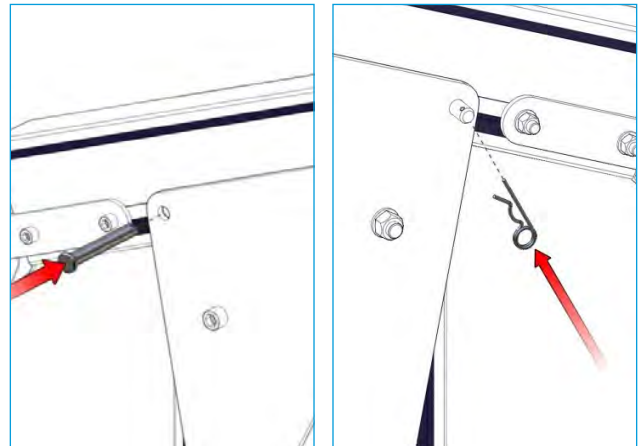

5. Inserting the clevis pin to take the weight of the beam and **secure the pin with the R-clip**. The T-DAVIT assembly is now complete; if using a winch continue onto winch assembly.

## Assembling the winch

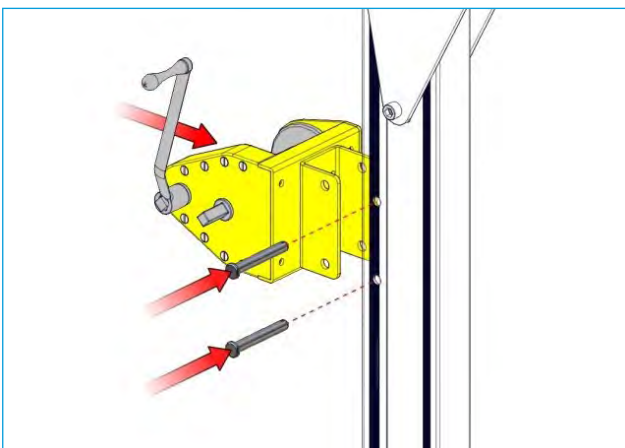

6. The T-Davit has the option to install a winch on the column as illustrated in the image. **Ensure the clevis pins are secured in place using the Rclips.**

**N.B. Winch is for illustration only; winch installation may differ. Contact your sales representative for more details.**

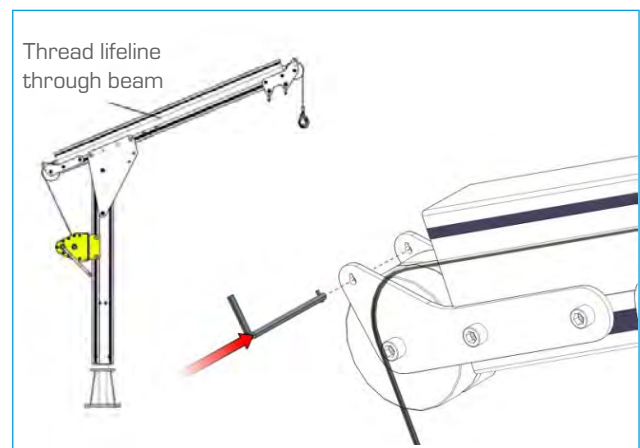

7. Thread the winch wire over the sheaves and through the beam as shown.

The wire rope retaining pins need to be removed to fit the rope in the sheave then reinserted ensuring they are secure.

For disassembly, reverse steps 1-7.

## ACCREDITATIONS

Quality and Safety are key themes throughout this document and the REID Lifting ethos. It is with this in mind that we have undertaken external accreditations to ensure we stay focused on what is important to our clients and users and ahead of market trends and developments in Safety and Quality systems.

REID Lifting has been successfully audited by Lloyds Register (LRQA) for approval of its Integrated Management System combining quality systems management, environmental issues and the Health and Safety practices within the company.

### REID Lifting holds the following certifications:

- **ISO 9001** - Specifies requirements for a quality management system for any organisation that needs to demonstrate its ability to consistently provide product that meets customer and applicable regulatory requirements and aims to enhance customer satisfaction.
- **Article 11B** - Specifies a quality management system to comply with the strict requirements of producing a product to the PPE Directive of 89/686/EEC.
- **ISO 14001** - Specifies the requirements for implementing environmental management systems throughout all areas of the company.
- **OHSAS 18001** - Occupational Health and Safety Managements Systems.
- **LEEA Membership** - REID Lifting Ltd is a full member of the Lifting Equipment Engineers Association (membership 000897). REID Lifting conforms to the main aims of the association which is to achieve the highest standards of quality and integrity in the operations of members. Their entry qualifications are demanding and strictly enforced through technical audits based on the technical requirements for members.

### Conformité Européenne (CE)

REID Lifting's products have been designed, tested and approved (as appropriate) by the Conformité Européenne. This certifies that REID Lifting's products meet the demands of the European Directives regarding health and safety requirements.

### The Queen's Award for Enterprise Innovation

REID Lifting has been awarded this prestigious award twice for innovative design and development of lightweight, portable and safe lifting solutions.



### TESTING

Testing and Technical File review are integral parts of our design and manufacturing process – to externally verify the products, where appropriate, using government approved Notified Bodies.

All REID Lifting products are type tested at laboratories that are accredited by the United Kingdom Accreditation Service (UKAS). In addition products are proof load tested either individually (or on a batch sampling basis).

Full product design & development Technical Files are available for inspection.

### Product IPR

Intellectual property rights apply to all REID Lifting Ltd products. There are patents in place, or pending, for:

- *PORTA-GANTRY*
- *PORTA-GANTRY RAPIDE*
- *PORTA-DAVIT QUANTUM*
- *T-DAVIT*
- *SNAPPER*

All product names are trade-marks of REID Lifting Ltd:

- *PORTA-GANTRY*
- *PORTA-GANTRY RAPIDE*
- *PORTA-DAVIT*
- *PORTA-BASE*
- *T-DAVIT*
- *PORTA-QUAD*
- *SNAPPER*
- *PORTA-LIFTER* Manhole Lifter

#### **UK**

REID Lifting  
Unit 1 Wyeview  
Newhouse Farm Ind. Estate  
Chepstow, Monmouthshire  
NP16 6UD, UK  
Tel: +44 (0)1291 620 796  
Fax: +44 (0)1291 626 490  
sales@reidlifting.com  
www.reidlifting.com

#### **FRANCE**

REID Lifting France  
P.A. de Kerboulard  
Rue Gutenberg  
56250 Saint-Nolff  
France  
Tel: +33 (0)297 53 32 99  
Fax: +33 (0)297 53 04 86  
contact@reidlifting.fr  
www.reidlifting.fr

#### **DE & AUT & CH**

REID Lifting D-A-CH  
Finkernstrasse 26  
8280 Kreuzlingen  
Switzerland  
Tel: +41 (0)71 686 90 40  
Fax: +41 (0)71 688 51 69  
jesser@reidlifting.de  
www.ecolistec.ch  
www.reidlifting.de

#### **SWEDEN**

JJ Gruppen  
Box 74, Rällarvägen 15  
184 21 Åkersberga  
Sweden  
Tel: +46 (0)8540 69180  
Fax: +46 (0)8540 60566  
kamab@jjgruppen.se  
www.jjgruppen.se

#### **USA & CANADA**

Thern, Inc.  
5712 Industrial Park Road  
PO Box 347  
Winona, MN 55987, USA  
Tel: +1 507 454 2996  
Fax: +1 507 454 5282  
info@thern.com  
www.thern.com

#### **AUSTRALIA**

Vector Lifting  
43 Spencer Street  
Jandakot  
WA 6164, Australia  
Tel: +61 (0)8 9417 9128  
Fax: +61 (0)8 9417 4105  
info@vectorlifting.com.au  
www.vectorlifting.com.au

#### **TEL**

+44 (0)1291 620796

#### **EMAIL**

sales@reidlifting.com

#### **WEB**

www.reidlifting.com



WEB

